

# 179083-15

(Varenr. 177040)



# PLUS

PLUS A/S

Ådalen 13B

DK-6600 Vejen

phone: +45 7996 3333

web: [www.plus.dk](http://www.plus.dk)

[plus@plus.dk](mailto:plus@plus.dk)

*Vi anbefaler at være to personer til samling af dette produkt.  
Wir empfehlen, dass die Montage des Produktes von zwei Personen durchgeführt wird.  
We recommend two people to assemble this product.  
Vi rekommenderar att man är två personer för montering av produkten.  
Nous vous recommandons d'être à deux pour procéder à l'assemblage du produit.*

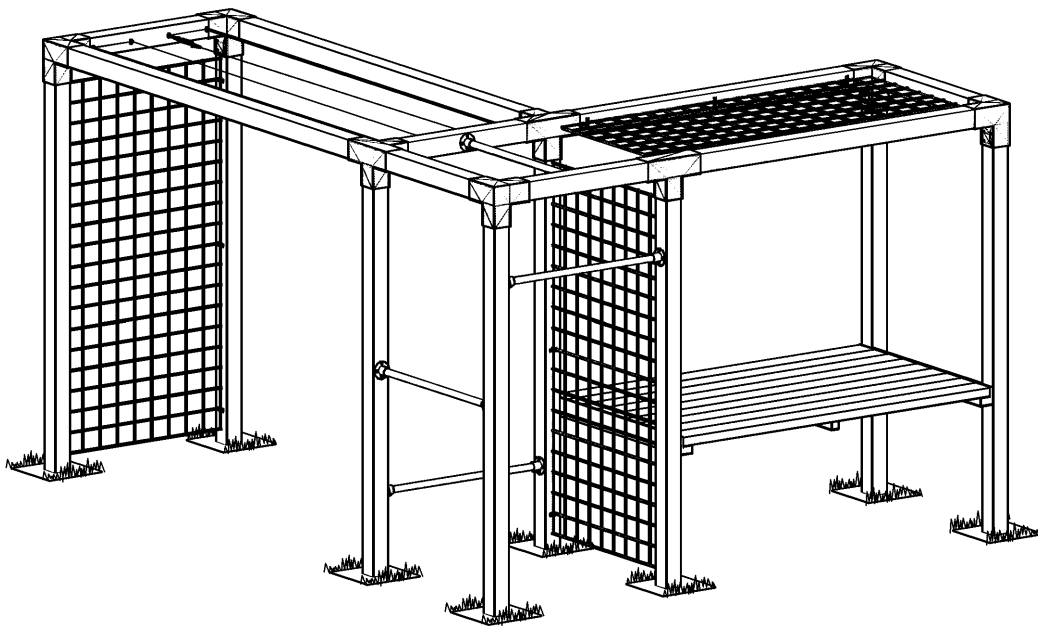

Kun til privat brug.  
Nur für privaten  
Gebrauch.  
For private use only.  
Endast för privat bruk  
Pour usage privé  
uniquement

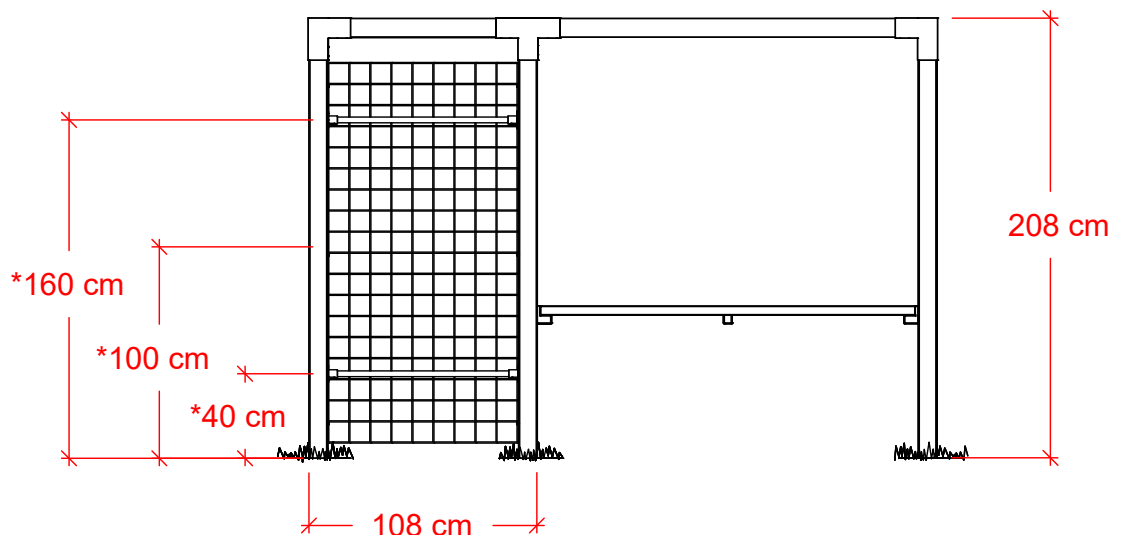

- DK: \* Placering af stænger vil være individuelt alt efter øvelser.  
DE: \* Die Stangen können individuell je nach Übung platziert werden.  
UK: \* Positioning of bars will be individual depending on exercises.  
SE: \* Placering av stänger väljs individuellt utifrån typ av träning.  
FR: \* L'emplacement des barres se fait individuellement en fonction de la situation.

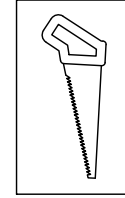
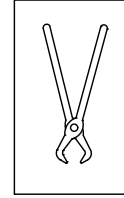
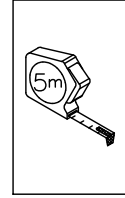
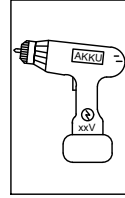
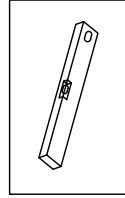
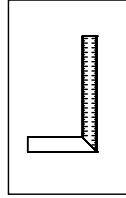
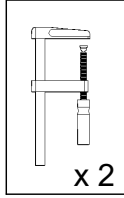
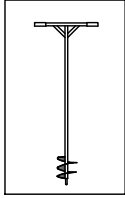
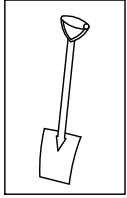

1 x 17963-15 (3690 mm)



2 x 20470-15 (2980 mm)



9 x 20469-15 (2680 mm)

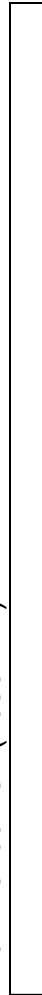

2 x 17956-15 (900 mm)

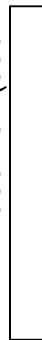

3 x 961617 (90x180 cm)

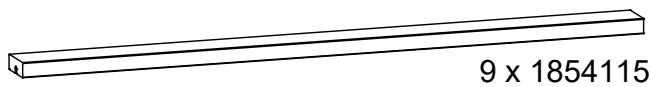
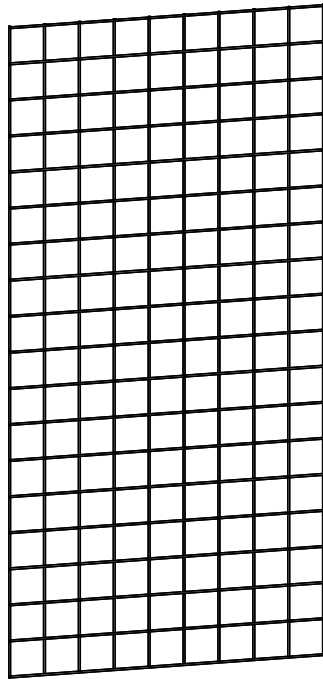

9 x 1854115



2 x 18540315



1 x 18540215

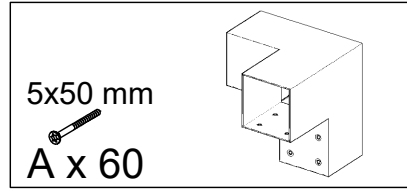

5 x 17971-15

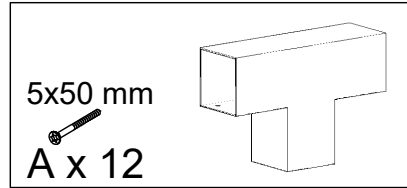

1 x 17972-15

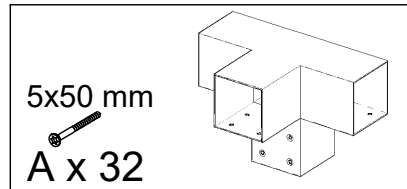

2 x 17973-15



8 x T-131-A27



1 x T-INB-AB



4 x B-075-235 L900

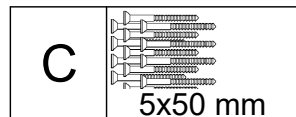

2 x 17518-1

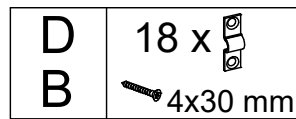

3 x 0247-15

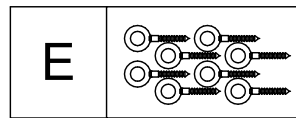

1 x 8596

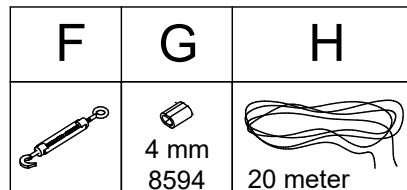

1 x 18425

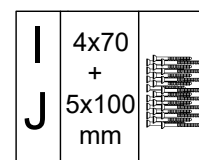

1 x 185401

### **PLACERING:**

Fitness stativet placeres på et plant område, der skal være mindst 1,5 meter fri rundt omkring stativet (træer, huse m.m.).

Underlaget bør overholde kravene til støddæmpning.

Græs har udmærkede støddæmpende egenskaber, hvis det vedligeholdes ordentligt. (Grønt, trimmet og godt rodet).

Ellers kan der anvendes løst underlag f.eks. grus, bør det være 40 cm dybt.

Desuden findes der produkter som barkflis og gummimåtter.

Placer aldrig fitness stativet på materialer som fliser og asfalt.

Kontroller jævnligt stativet - stramning af samlinger eller udskiftning af slidte eller defekte dele. Samt vedligeholdelse af stødabsorberende underlag.

Advarsel:

Tøj med hætter bør være uden snore, da børn kan blive kvalt i disse snore, hvis de sætter sig fast. Ligesom man bør undgå halstørklæder og lignende.

### **PLACERING:**

Placera motionsstället på en plan yta med minst 1,5 meter fritt utrymme runt stativet (träd, hus etc.).

Underlaget ska uppfylla kraven på stötdämpning.

Gräs har utmärkta stötdämpande egenskaper om det underhålls på rätt sätt. (Grönt, trimmat och väl rotat).

Annars kan ett löst underlag användas, t.ex. grus, om det är 40 cm djupt.

Det finns även produkter som kompost och gummimattor.

Placera aldrig träningsstället på material som kakel och asfalt.

Kontrollera stativet regelbundet - dra åt fogar eller byt ut slitna eller defekta delar. Likaså underhåll av stötdämpande ytor.

Varning för klädsel:

Kläder med huvor bör vara utan snören eftersom barn kan kvävas av dessa snören om de fastnar.

Likaså bör halsdukar och liknande undvikas.

### **PLATZIERUNG:**

Der Fitnessstand sollte auf einer ebenen Fläche platziert werden. Es muss ein Sicherheitsabstand von mindestens 1,5 Meter rund um den Fitnessstand eingehalten werden (Bäume, Haus u.a.)

Der Untergrund sollte die Anforderungen der Stoßabsorbierung erfüllen.

Gras hat hervorragende stoßdämpfende Eigenschaften, wenn es richtig gepflegt wird. (Grün, getrimmt und ein gutes Wurzelwerk).

Sofern ein loser Untergrund angewendet wird, wie z. Bsp. Kies, muss dieser mindestens 40 cm tief sein.

Des Weiteren gibt es Produkte wie Rindenmulch oder Gummimatten.

Stellen Sie den Fitnessstand niemals auf Materialien wie Beton oder Asphalt.

Überprüfen Sie den Ständer regelmäßig - ziehen Sie Verbindungen fest oder ersetzen Sie verschlissene oder defekte Teile.

Sowie Pflege von stoßdämpfenden Oberflächen.

Achtung:

Kleidung mit Kapuzen sollte ohne Schnur sein, da sich diese verfangen können. Auch sollte der Gebrauch von Schals oder ähnlichen vermieden werden.

## **LOCATION:**

The fitness stand is placed on a level area that must be at least 1,5 meters free around the stand (trees, houses, etc.).

The substrate should comply with the requirements for shock absorption.

Grass has excellent shock-absorbing properties if properly maintained.

(Green, trimmed and well rooted).

Otherwise, a loose base can be used, e.g. gravel, it should be 40 cm deep.

In addition, there are products such as bark chips and rubber mats.

Never place the fitness stand on materials such as tiles and asphalt.

Check the fitness stand regularly - tightening joints or replacing worn or defective parts.

As well as maintenance of shock-absorbing surfaces.

## **Warning:**

Clothes with hoods should be without cords, as children can be suffocated in these cords if they get stuck. Just as one should avoid scarves and the like.

## **EMPLACEMENT :**

Placez le stand de fitness sur une surface plane avec un espace libre d'au moins 1,5 mètre autour du stand (arbres, maisons, etc.).

La surface doit répondre aux exigences en matière d'absorption des chocs.

L'herbe a d'excellentes propriétés d'absorption des chocs si elle est correctement entretenue.

(verte, taillée et bien enracinée).

Sinon, un substrat meuble peut être utilisé, par exemple du gravier, à condition qu'il ait une profondeur de 40 cm.

Il existe également des produits tels que le paillis et les tapis en caoutchouc. Ne placez jamais le support de fitness sur des matériaux tels que le carrelage ou l'asphalte.

Contrôlez régulièrement le support, en resserrant les joints ou en remplaçant les pièces usées ou défectueuses.

Ainsi que l'entretien des surfaces amortissant les chocs.

## **Attention:**

Les vêtements à capuche doivent être dépourvus de ficelles, car les enfants peuvent s'étouffer avec ces ficelles si elles s'accrochent.

De même, les écharpes et autres foulards sont à éviter.

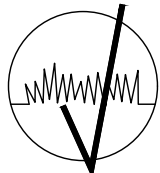
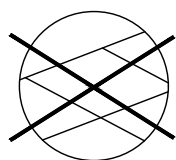

DK: Anbefalet udbredelse af stødområde.

SE: Rekommenderad utbredning av påverkansområdet.

DE: Empfohlene Erweiterung des Fallbereiches.

UK: Recommended distribution of impact area.

FR: Étendue recommandée de la zone d'impact.

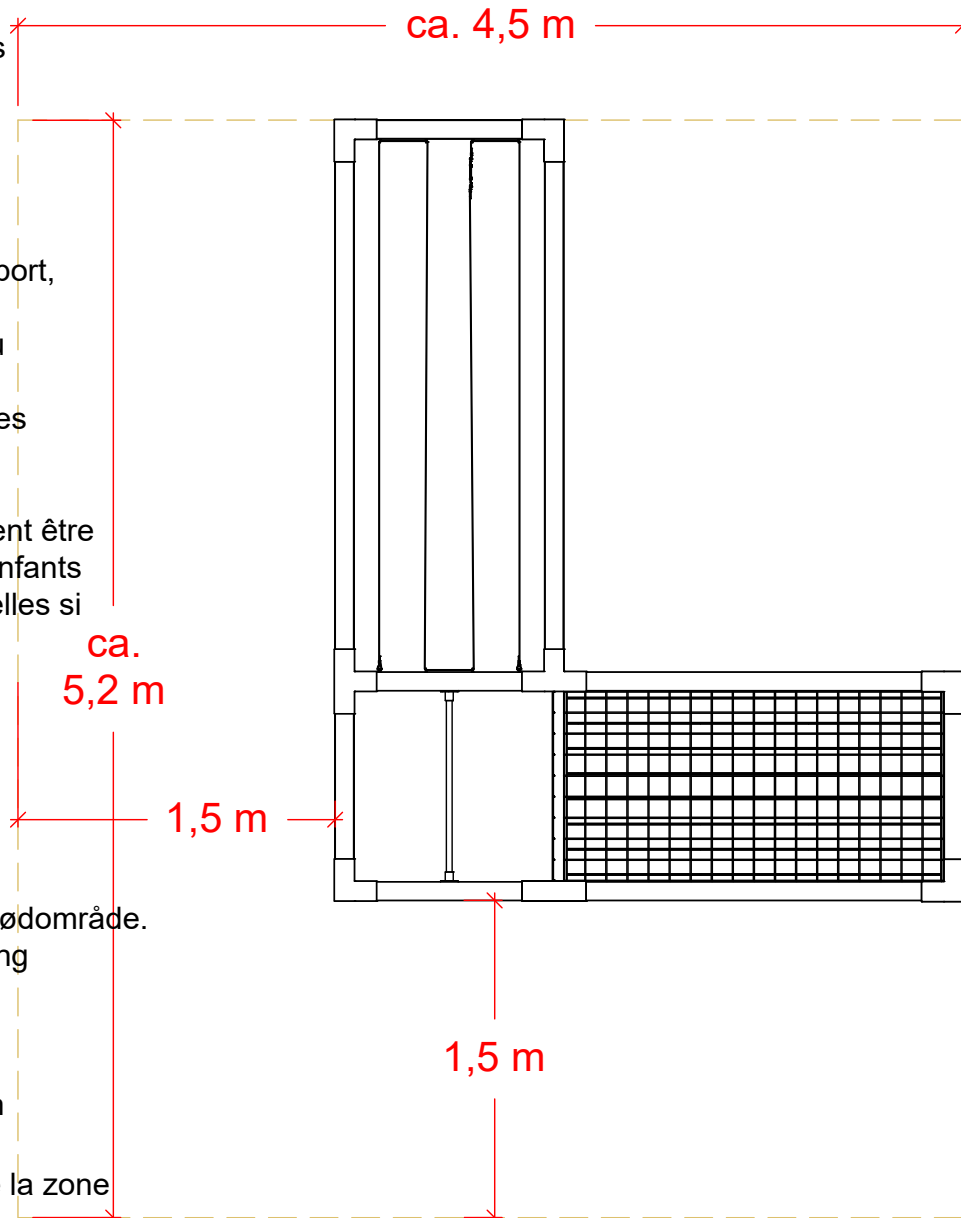

DK: Ved lerjord anbefaler vi 10 cm småsten i bunden som dræn.

Jorden omkring stolpen, stemples til med en lægte eller lignende.

SE: För lerjord rekommenderar vi 10 cm småsten i botten som dränering.

Stampa jorden runt stolpen med en läkt eller liknande.

DE: In Tonböden empfohlen wir 10 cm Kies in den Boden als Drainage.

Den Boden um die Pfosten mit einer Latte oder Ähnlichen feststampfen.

UK: In clay soils, we recommend 10 cm pebbles in the bottom as drainage. The soil around the post, tamped with a lath or something like that.

FR: Pour les sols argileux, nous recommandons 10 cm de cailloux au fond pour le drainage. Tassez le sol autour du poteau à l'aide d'une latte ou d'un objet similaire.

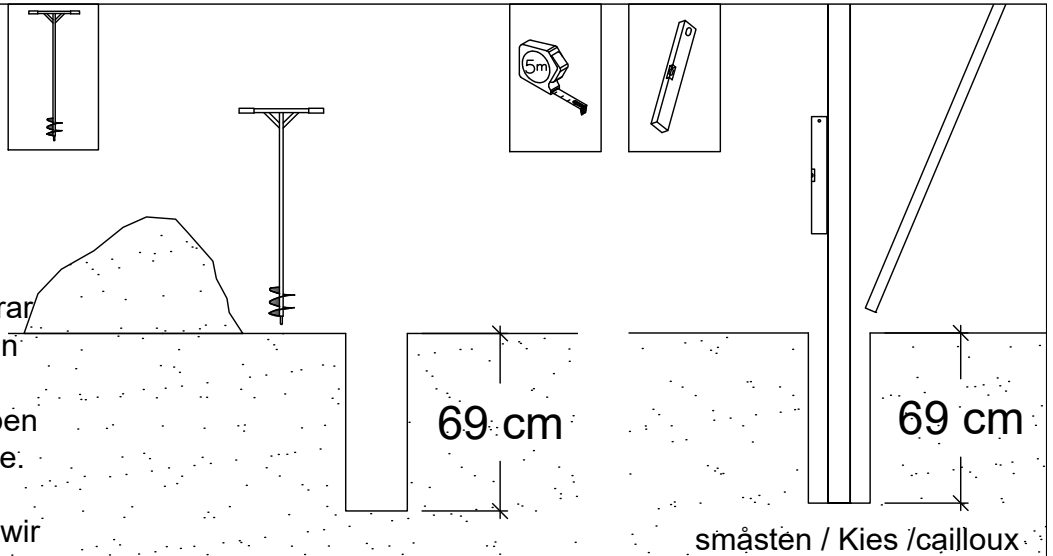

DK: Jorden stemples til, når alle dele er monteret og skruet fast.  
(Stolper, overligger, beslag og rio-net)

SE: Jorden stampas till när alla delar är monterade och fastskruvade.  
(Stolpar, överliggare, fästen och rionät)

DE: Nachdem alle Teile (Pfosten, Träger, Beschläge und Spalier) montiert sind soll der Boden um die Pfosten gut festgestampft werden.

UK: Tamp the ground when all parts are mounted and screwed in place.  
(Posts, lintels, brackets and rio net)

FR: Damez le sol une fois que toutes les pièces sont montées et vissées.  
(Poteaux, linteaux, fixations et filet rio)

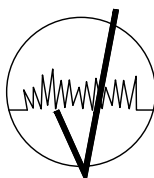
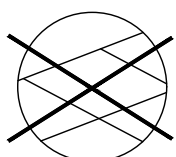
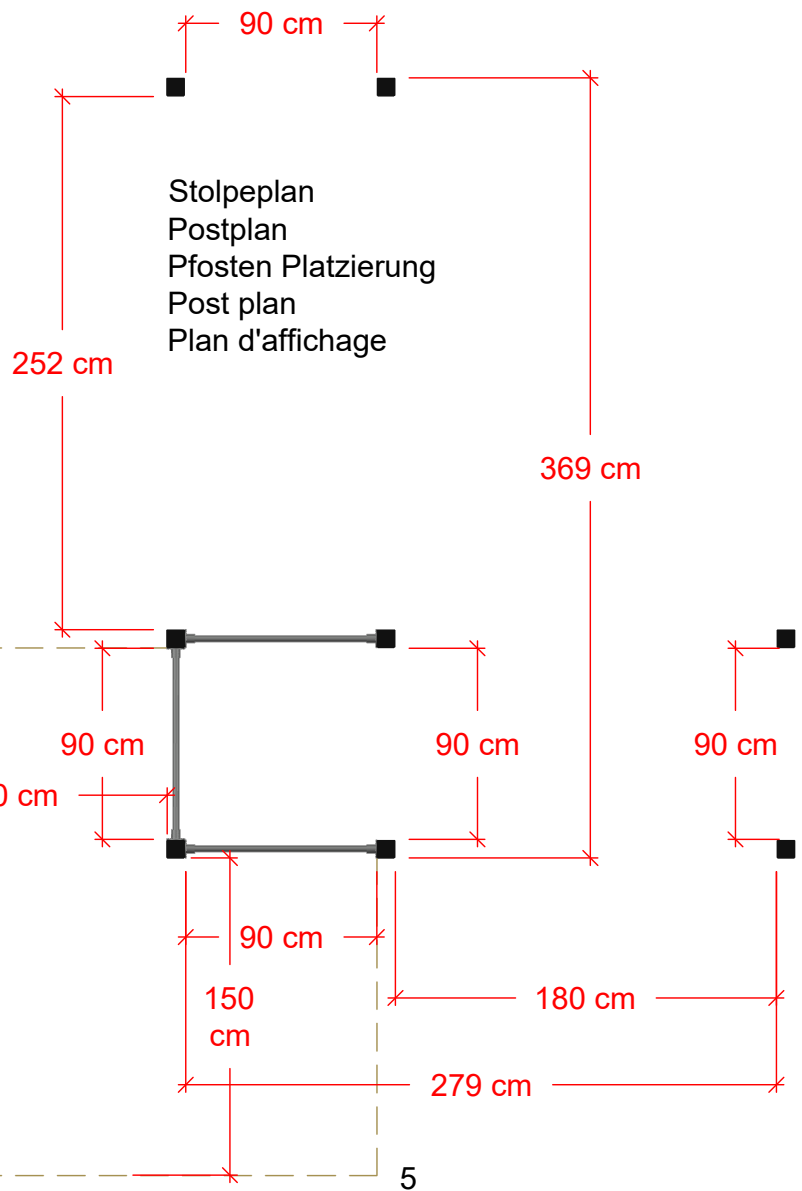

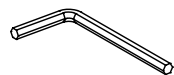
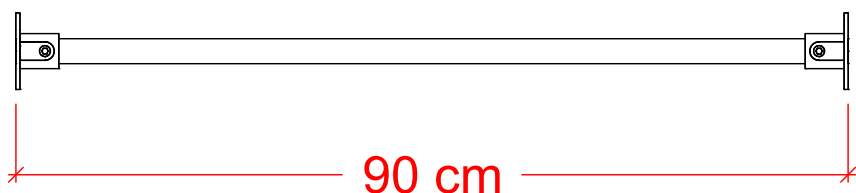

1 x T-INB-AB

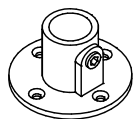

T-131-A27

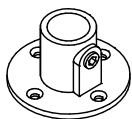

T-131-A27

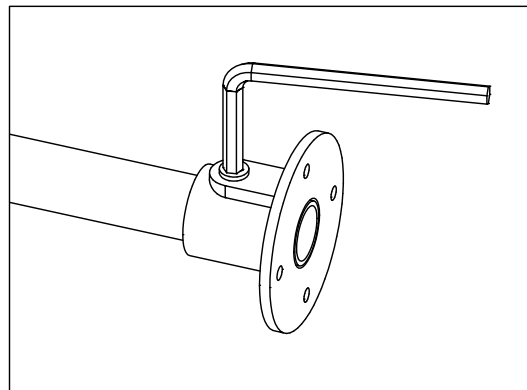

DK: Start med at samle alle stænger med muffer.  
Så de kan bruges til afstandsmåling mellem stolperne.

SE: Börja med att montera alla stolpar med hylsor.  
På så sätt kan de användas för att mäta avståndet mellan stolparna.

DE: Beginne damit, alle Stangen mit Hülsen zu versehen.  
So können sie verwendet werden, um den Abstand zwischen den Stangen zu messen.

UK: Start by assembling all poles with sleeves.  
So they can be used to measure the distance between the poles.

FR: Commencez par assembler tous les poteaux avec des manchons.  
Ils peuvent ainsi être utilisés pour mesurer la distance entre les poteaux.

DK: Beslagene monteres så \*unbraco lås vender nedad.

SE: Fästena monteras med \*unbraco-låset vänt nedåt.

DE: Die Halterungen werden so montiert, dass das  
\*Unbraco-Schloss nach unten zeigt.

UK: The brackets are mounted with the \*unbraco lock  
facing downwards.

FR: Les supports sont montés avec la serrure \*unbraco  
orientée vers le bas.

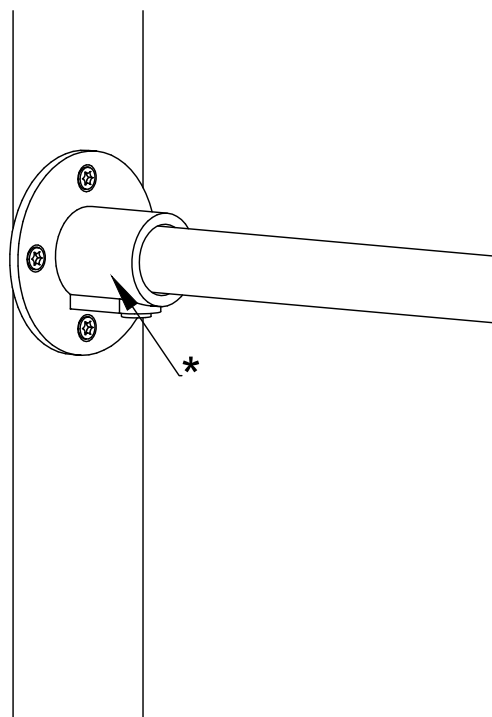

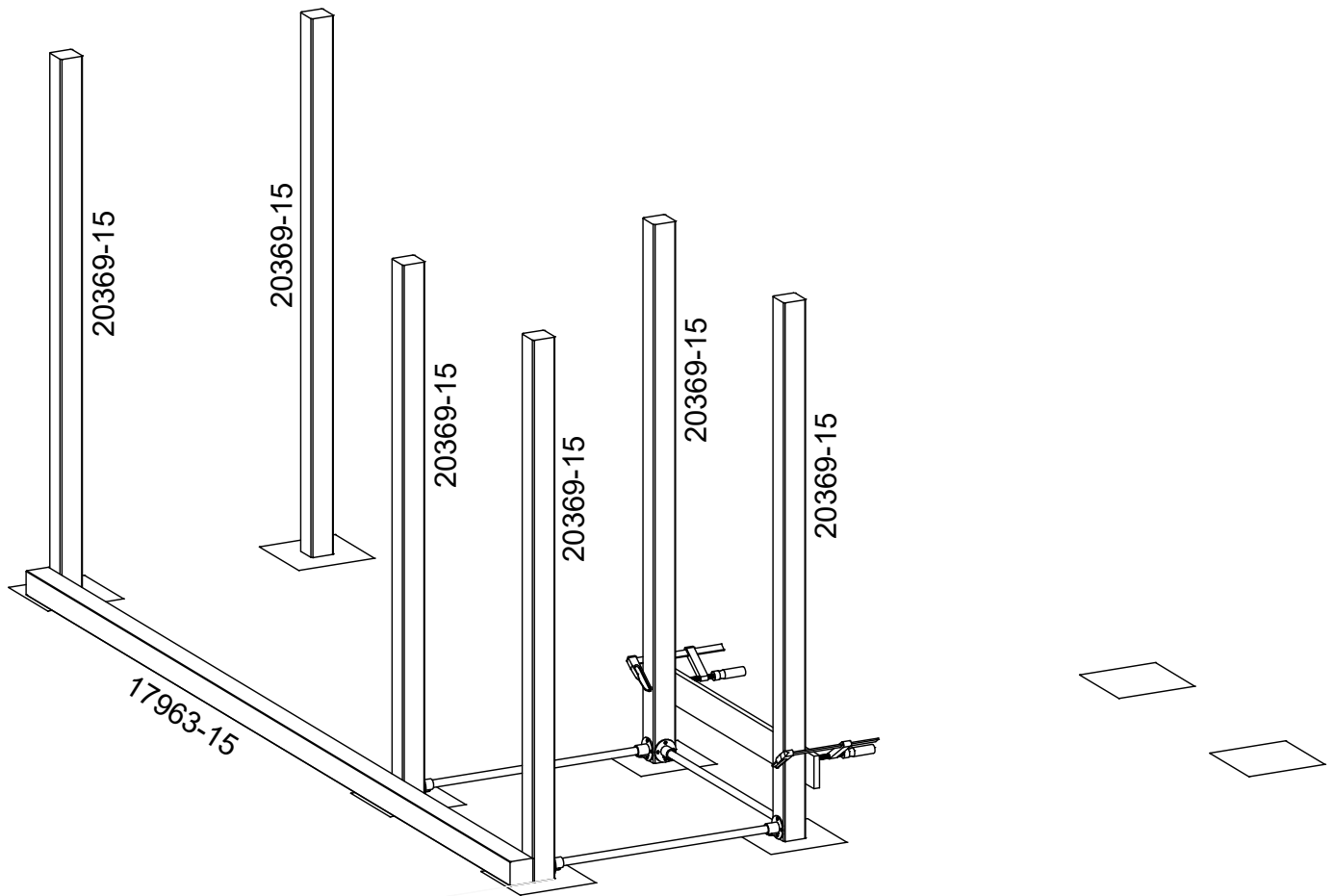
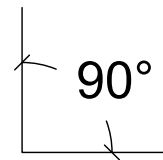
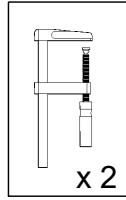
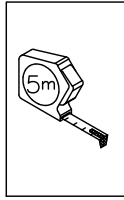
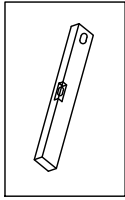
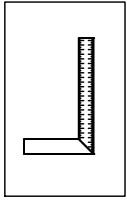

DK: Stænger samt evt. et bræt fastgjort med skruetvinger, kan bruges til at holde afstand og styring af stolper.

SE: Stolpar och eventuellt en bräda fäst med skruvklämmor kan användas för att hålla avstånd och styrning av stolparna.

DE: Stangen und eventuell ein mit Schraubzwingen befestigtes Brett können verwendet werden, um den Abstand und Steuerung der Pfosten.

UK: Poles and possibly a board attached with screw clamps can be used to keep distance and steering of posts.

FR: Des piquets et éventuellement une planche fixée à l'aide de colliers à vis peuvent être utilisés pour maintenir la distance et la direction des piquets. et la direction des poteaux.

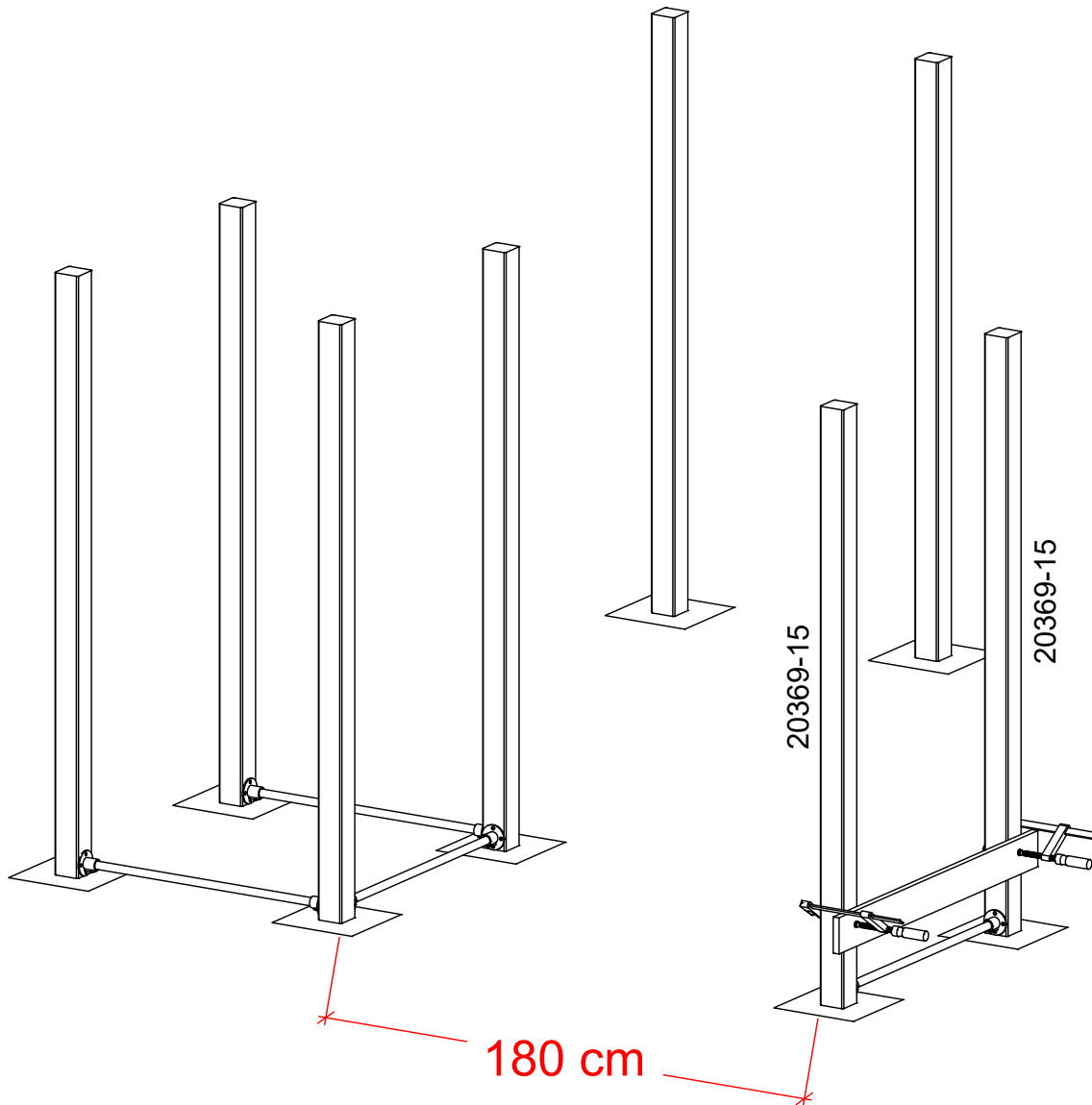
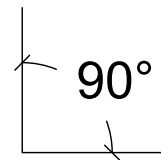
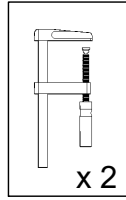
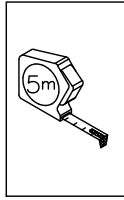
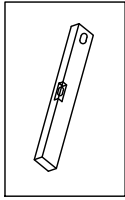
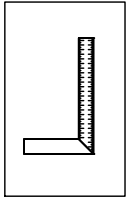

DK: Stænger samt evt. et bræt fastgjort med skruetvinger, kan bruges til at holde afstand og styring af stolper.

SE: Stolpar och eventuellt en bräda fäst med skruvklämmor kan användas för att hålla avstånd och styrning av stolparna.

DE: Stangen und eventuell ein mit Schraubzwingen befestigtes Brett können verwendet werden, um den Abstand und Steuerung der Pfosten.

UK: Poles and possibly a board attached with screw clamps can be used to keep distance and steering of posts.

FR: Des piquets et éventuellement une planche fixée à l'aide de colliers à vis peuvent être utilisés pour maintenir la distance et la direction des piquets. et la direction des poteaux.



DK: Vær opmærksom på, at dragerene kan have en krumning.  
Sørg for at vende krumningen opad ved montering, som vist på tegningen herunder.  
Træ er et naturmateriale og forandrer sig med vejr og vind, det er helt almindeligt.

DE: Beachten Sie, dass die Querbalken leicht gekrümmt sein können.  
Achten Sie darauf, dass die Krümmung bei der Montage nach oben zeigt, wie in der Zeichnung unten gezeigt.  
Holz ist ein natürliches Material und verändert sich mit der Witterung, das ist ganz normal.

UK: Please note that the girders may have a curvature.  
Make sure to face the curvature upwards when installing, as shown in the drawing below.  
Wood is a natural material and changes with the weather, this is normal.

SE: Observera att bjälkarna kan vara något krökta.  
Se till att vända krökningen uppåt vid montering, som på ritningen nedan.  
Trä är ett naturmaterial som förändras med väder och vind, och det är helt normalt.

FR: Sachez que les traverses peuvent avoir une courbure.  
Assurez-vous que la courbure soit orientée vers le haut lors du montage, comme indiqué sur le dessin ci-dessous.  
Le bois est un matériau naturel qui se modifie selon les conditions météorologiques.  
Cela est tout à fait normal.



DK: Accepteret krumning.

S: Accepterad krökning.

DE: Akzeptierte Krümmung.

F: Courbure acceptée.

UK: Accepted curvature.

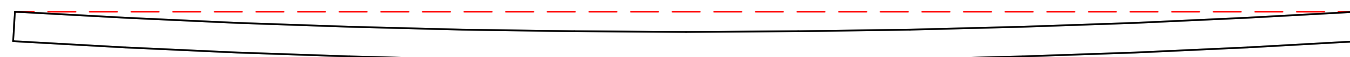
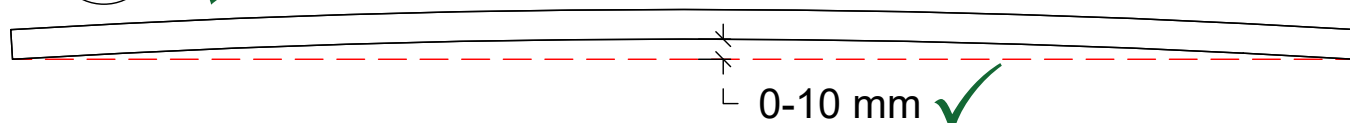

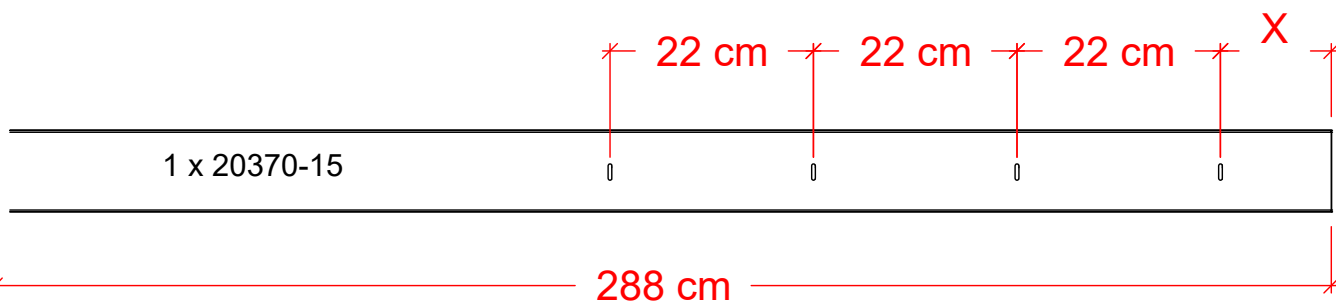
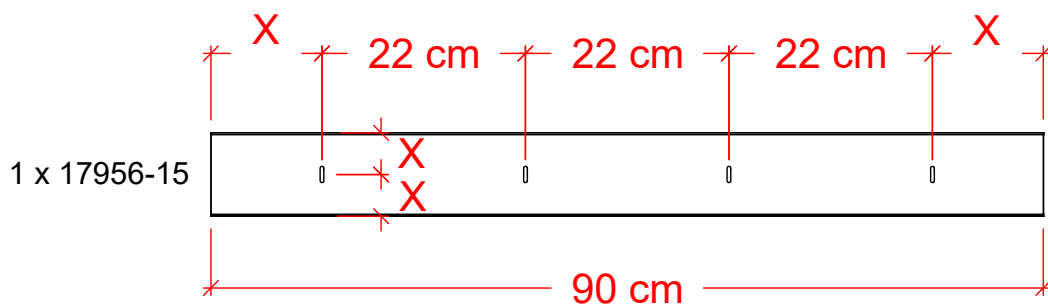
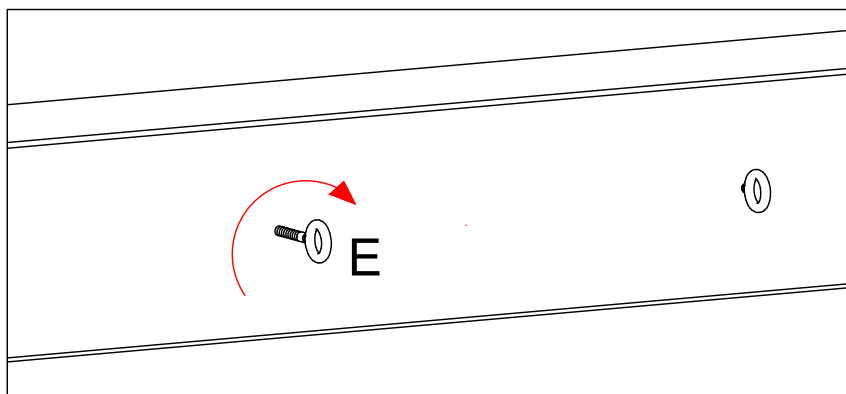
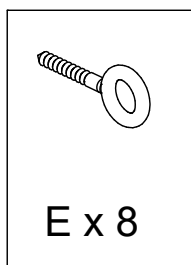
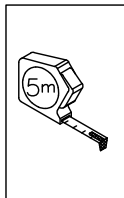
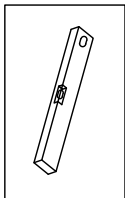

DK: 1x20469-15 + 2x20470-15 stolpe/overligger skal tilpasses - Se side 12+13.

SE: 1x20469-15 + 2x20470-15 stolpe/överliggare måste kundanpassas - se sid 12+13.

DE: 1x20469-15 + 2x20470-15 Pfosten/Sturz müssen individuell angepasst werden - siehe Seite 12+13.

UK: 1x20469-15 + 2x20470-15 post/lintel must be customised - See page 12+13.

FR: 1x20469-15 + 2x20470-15 poteau/linteau doivent être personnalisés - Voir page 12+13.

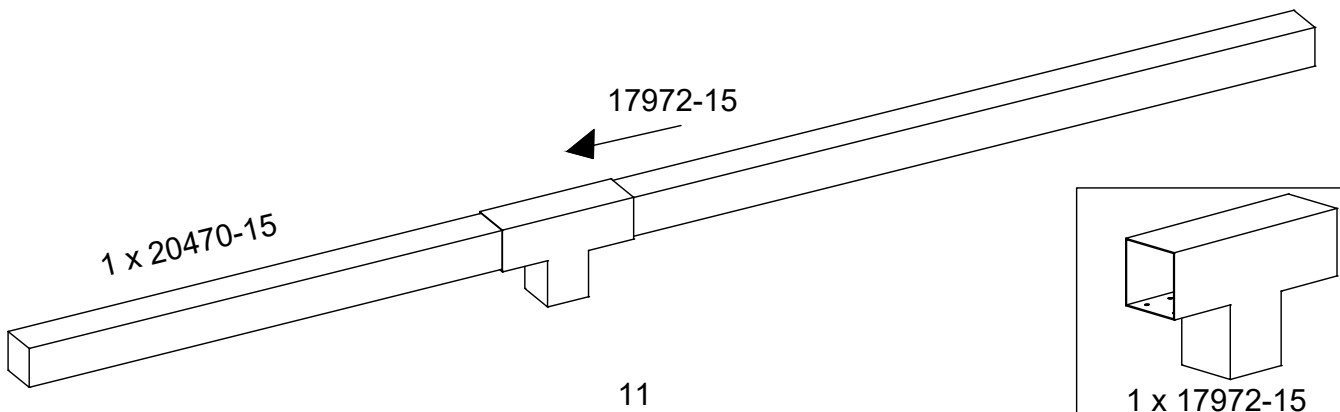
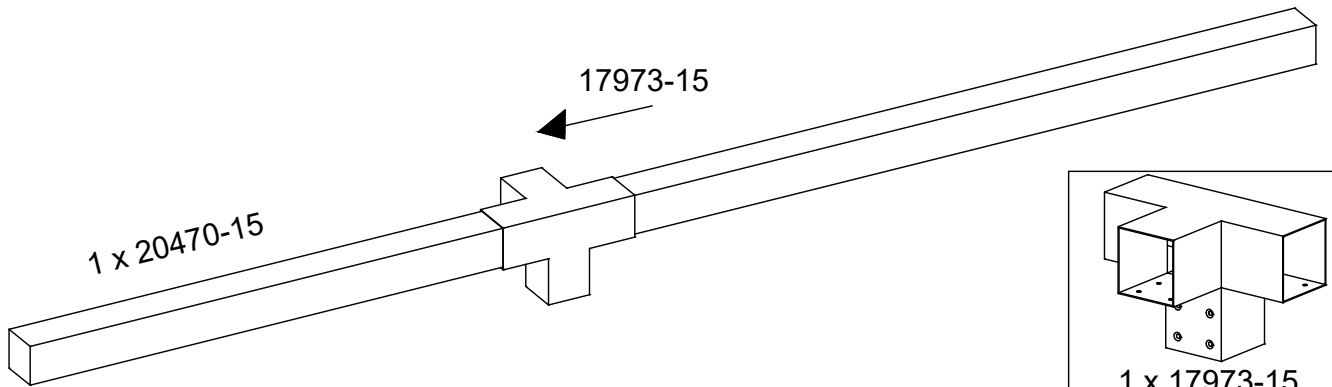
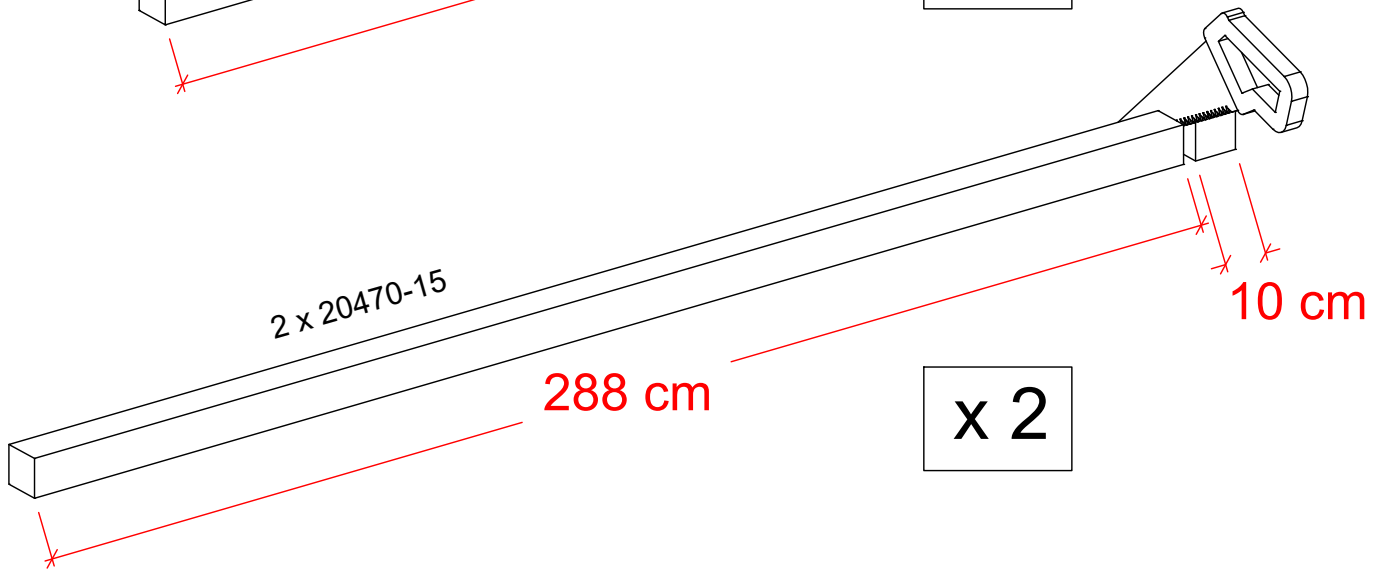
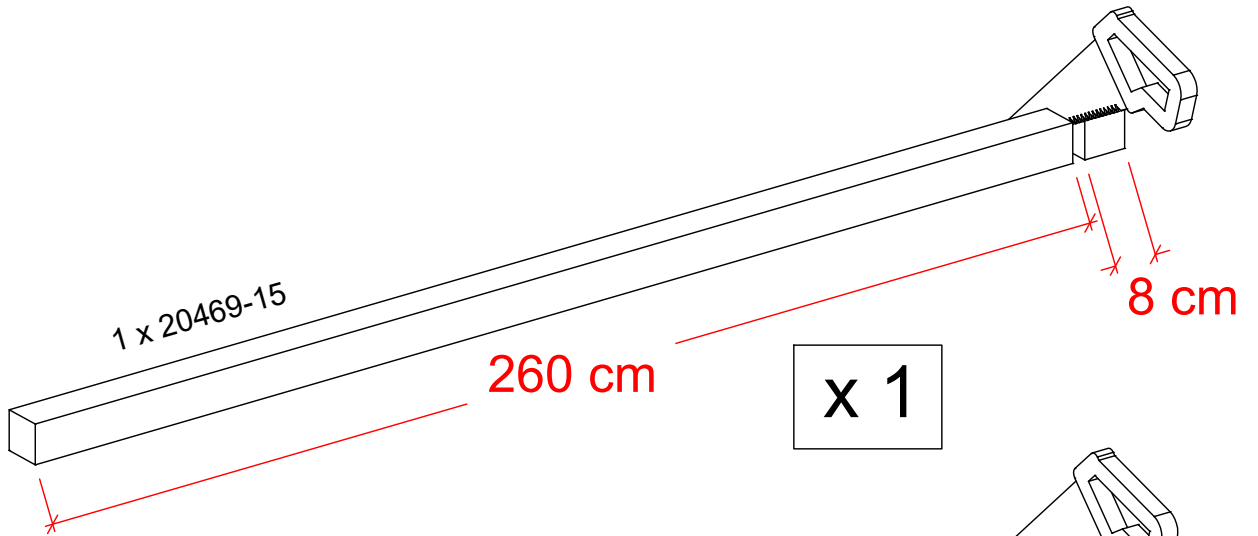
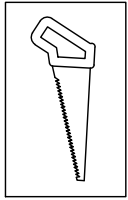

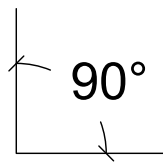
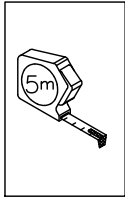
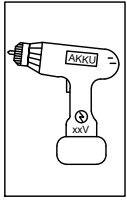

260 cm

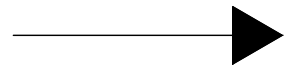
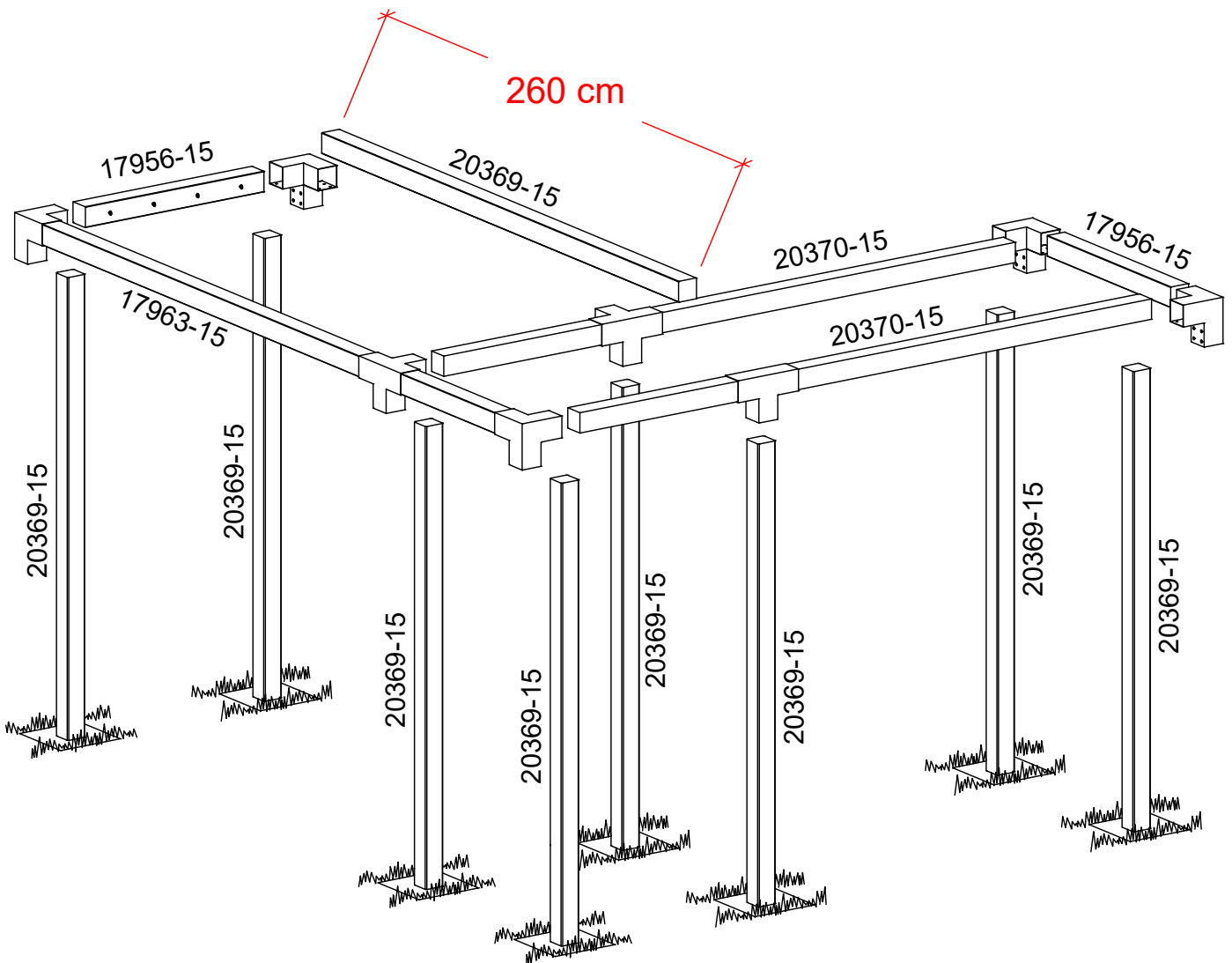

DK: Skruer strammes til, når ALLE dele er færdig samlet.

SE: Skruvarna dras åt när ALLA delar är monterade.

DE: Ziehen Sie die Schrauben fest, wenn ALLE Teile zusammengebaut sind.

UK: Tighten screws when ALL parts are fully assembled.

FR: Serrez les vis une fois que TOUTES les pièces sont assemblées.

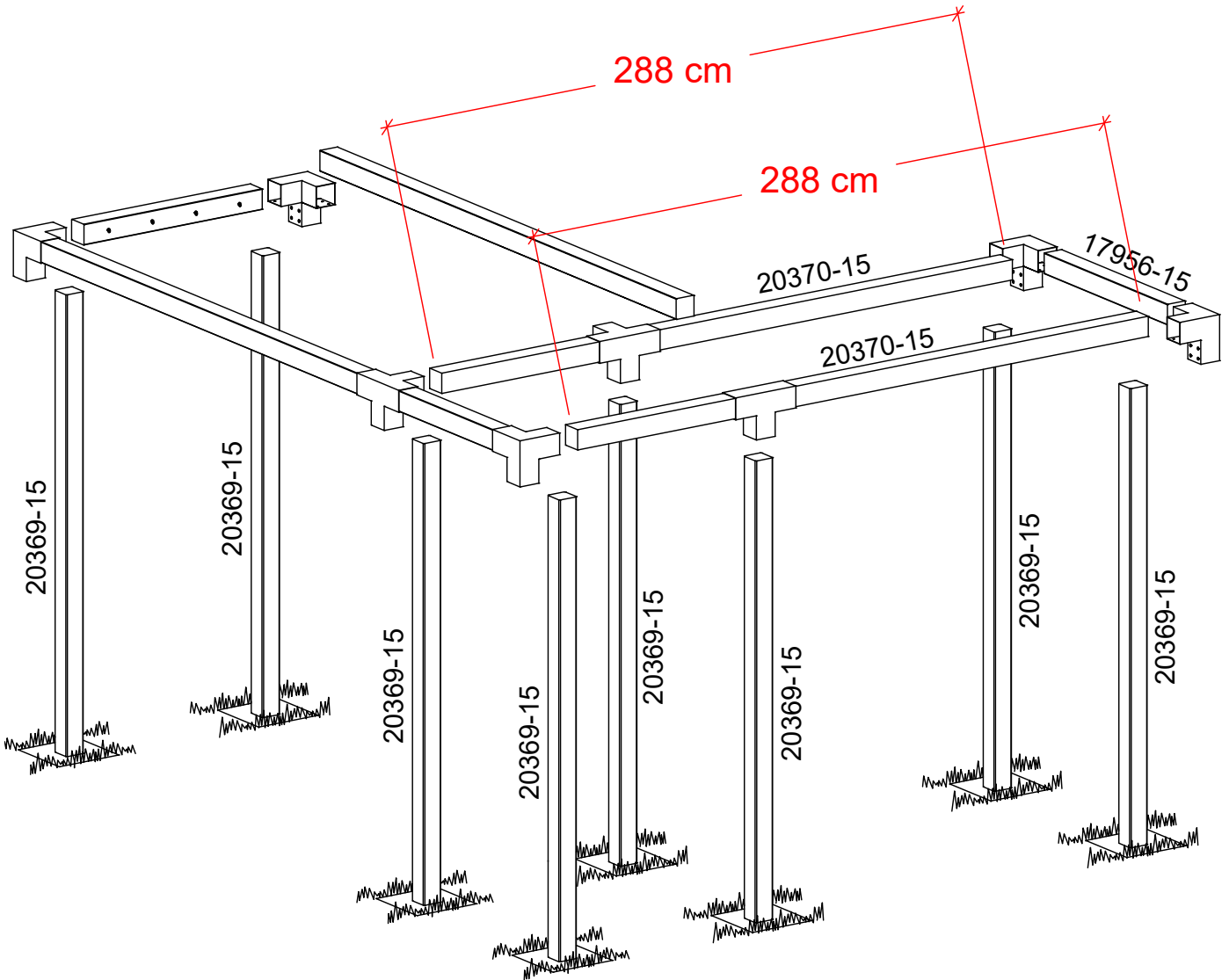
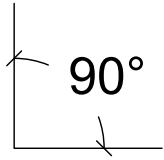
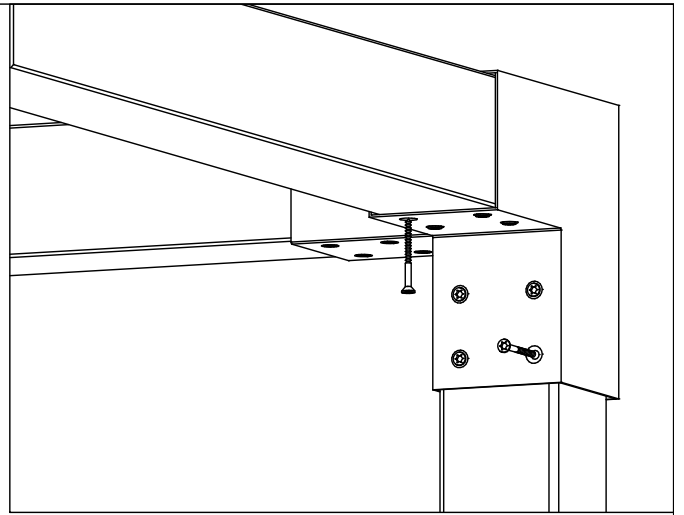
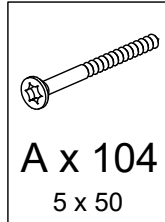
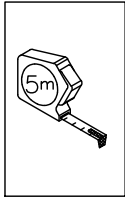
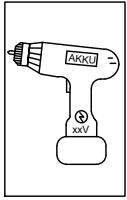

DK: Skruer strammes til, når ALLE dele er færdig samlet.

SE: Skruvarna dras åt när ALLA delar är monterade.

DE: Ziehen Sie die Schrauben fest, wenn ALLE Teile zusammengebaut sind.

UK: Tighten screws when ALL parts are fully assembled.

FR: Serrez les vis une fois que TOUTES les pièces sont assemblées.

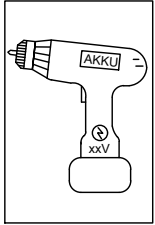
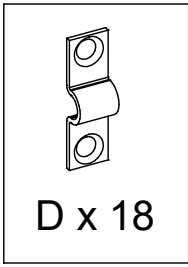
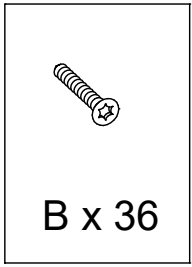

x 3

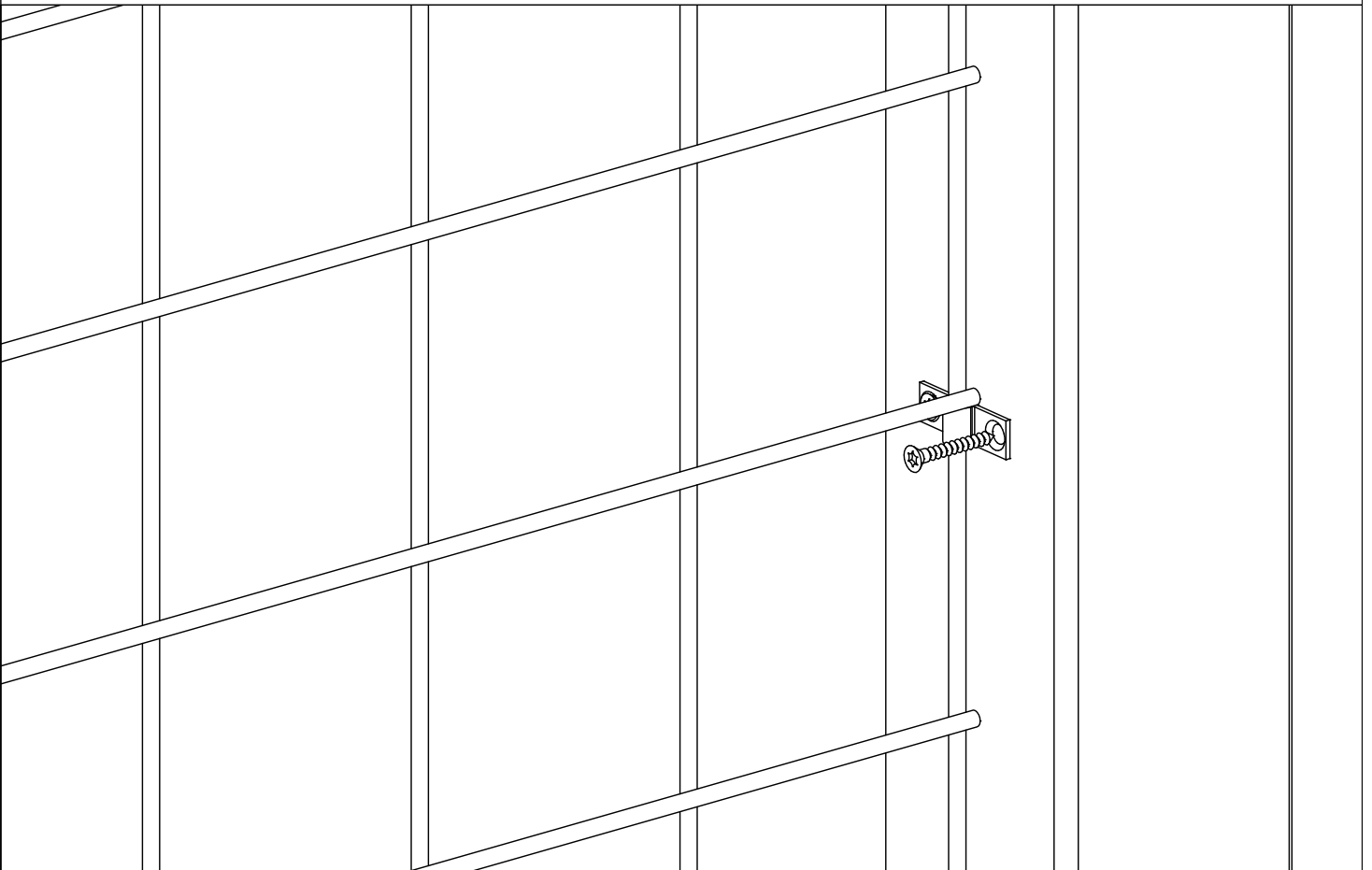
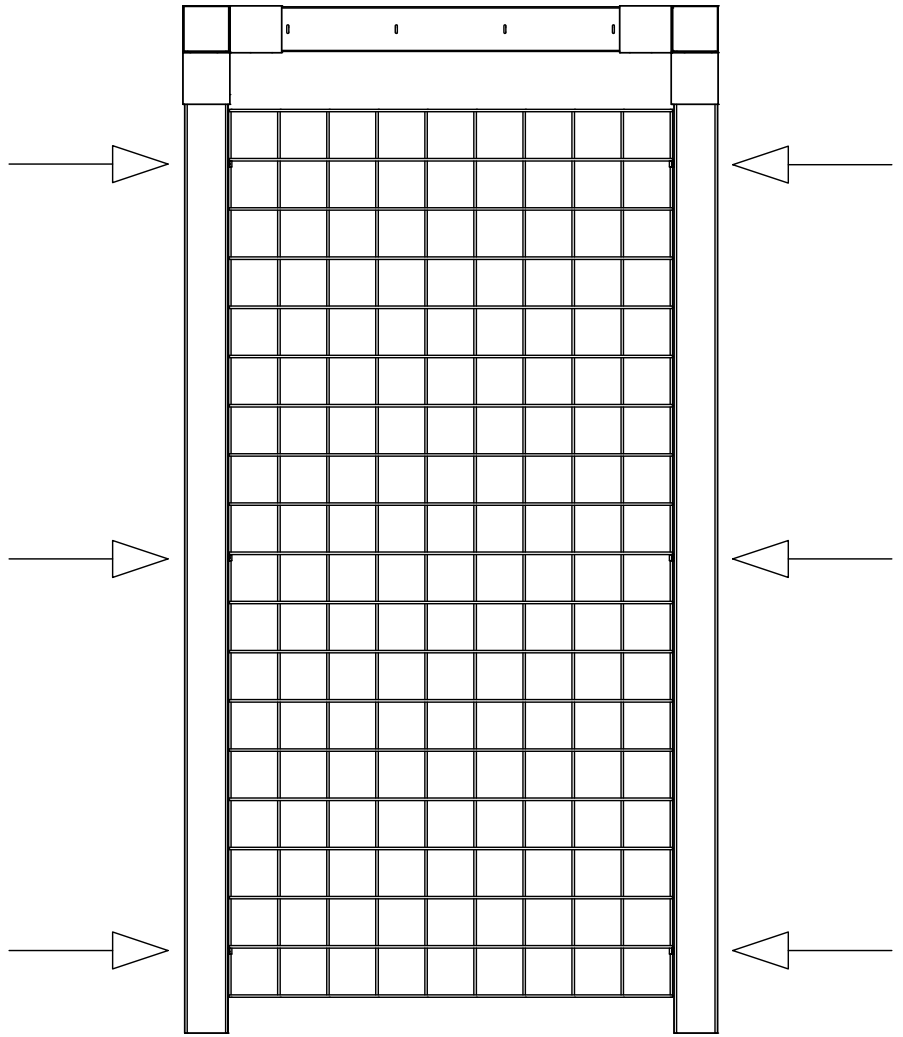

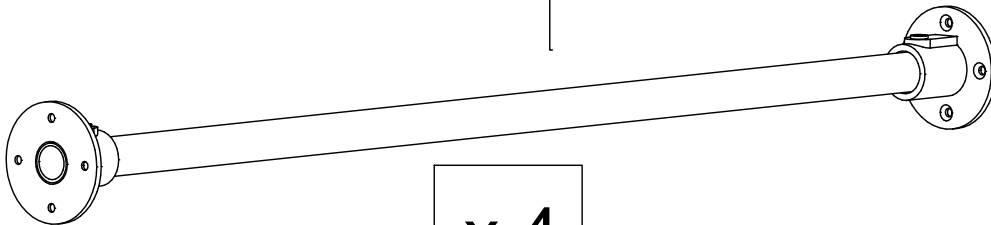
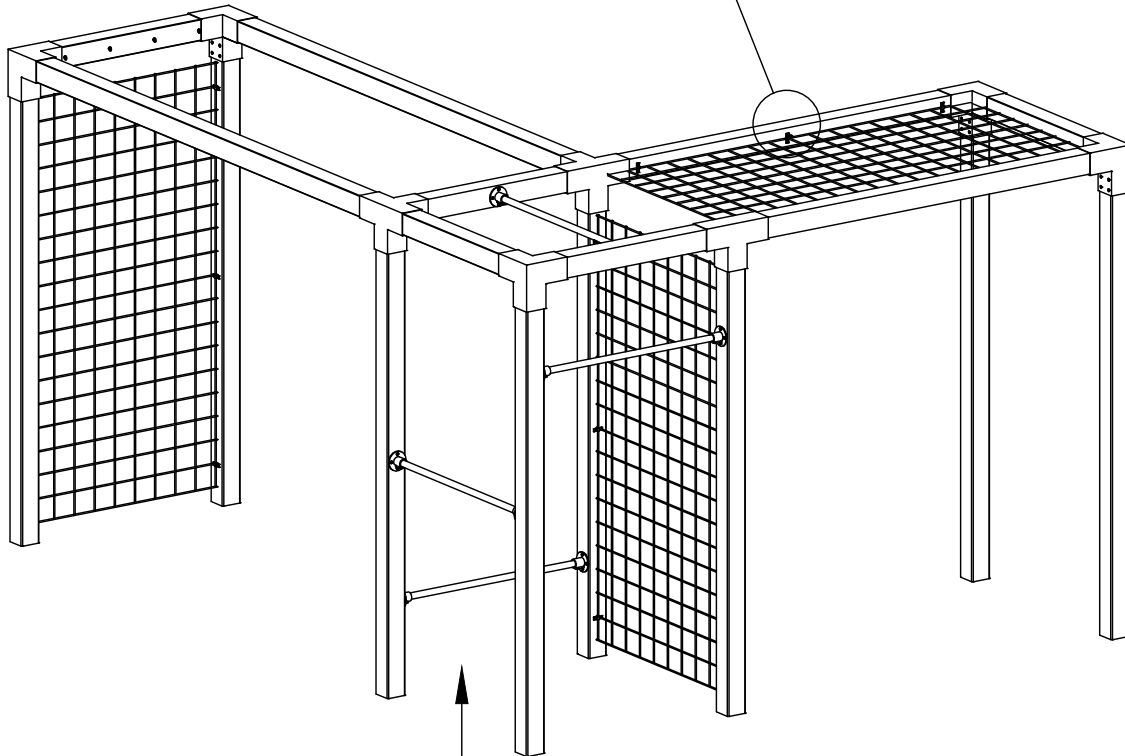
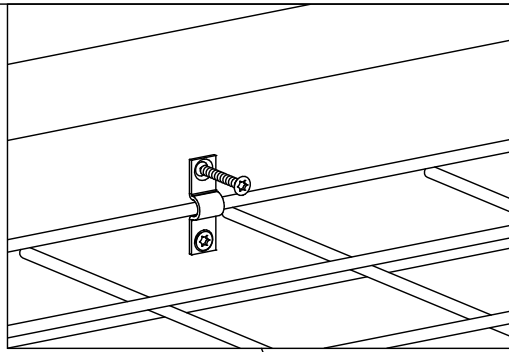

x 4

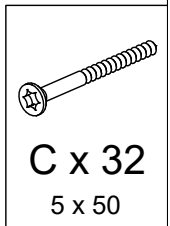

DK: Beslagene monteres så \*unbraco lås vender nedad.

SE: Fästena monteras med \*unbraco-låset vänt nedåt.

DE: Die Halterungen werden so montiert, dass das \*Unbraco-Schloss nach unten zeigt.

UK: The brackets are mounted with the \*unbraco lock facing downwards.

FR: Les supports sont montés avec la serrure \*unbraco orientée vers le bas.

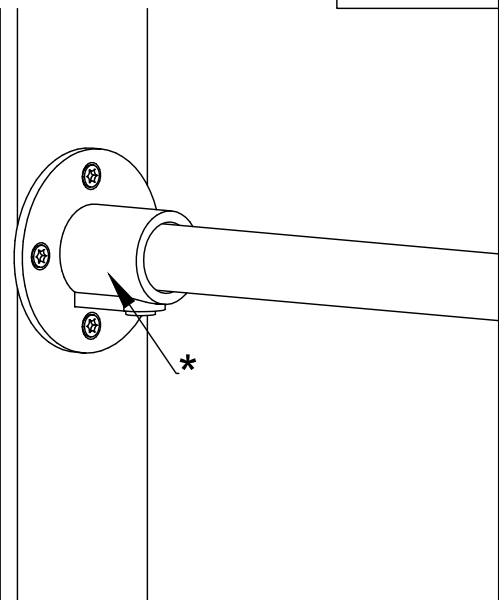

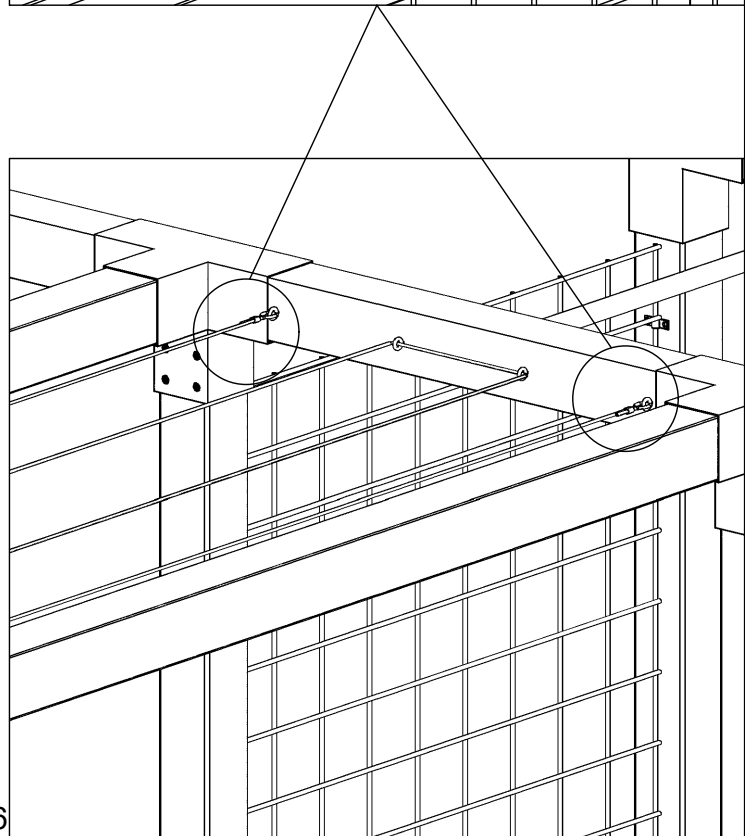
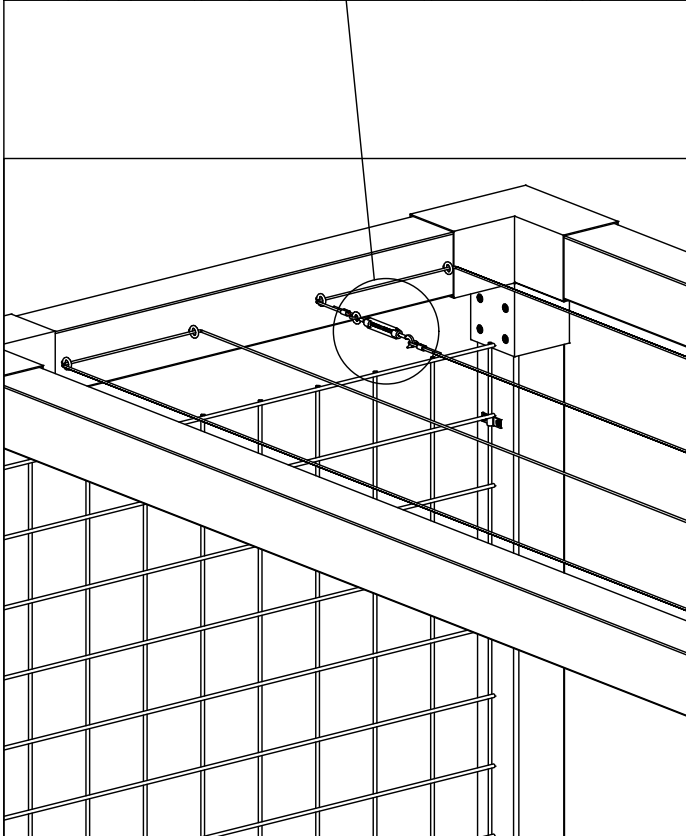
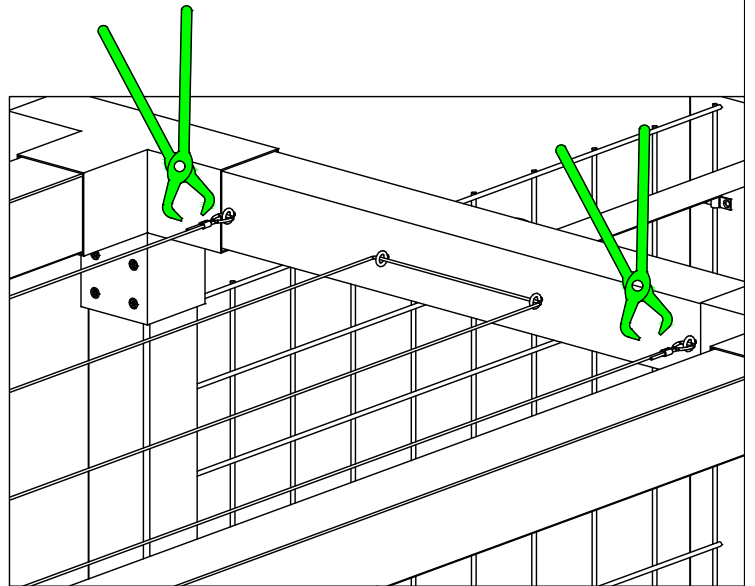
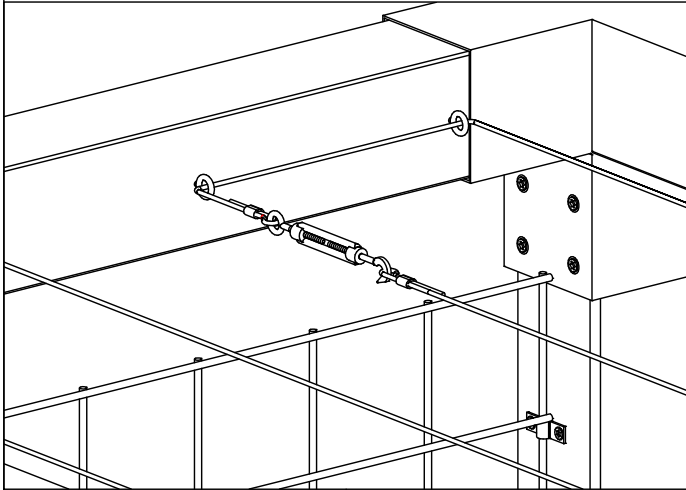
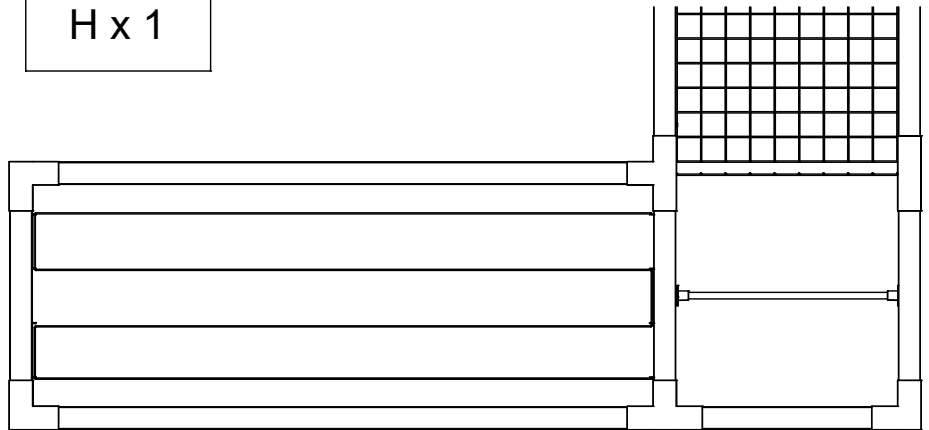
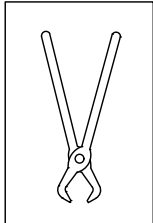
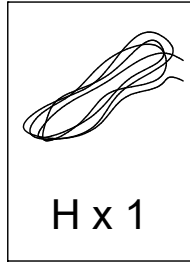
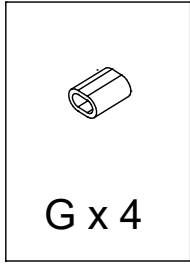
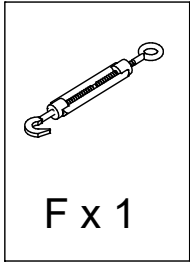





DK: Tørresnoren "brændes" i enderne, så den ikke trævler.

SE: Klädlinan är "bränd" i ändarna för att förhindra att den fransar sig.

DE: Die Trocknungsleine ist an den Enden "verbrannt", damit sie sich nicht auflöst.

UK: The clothesline is 'burnt' at the ends to prevent it from fraying.

FR: La corde à linge est « brûlée » aux extrémités pour éviter qu'elle ne s'effiloche.

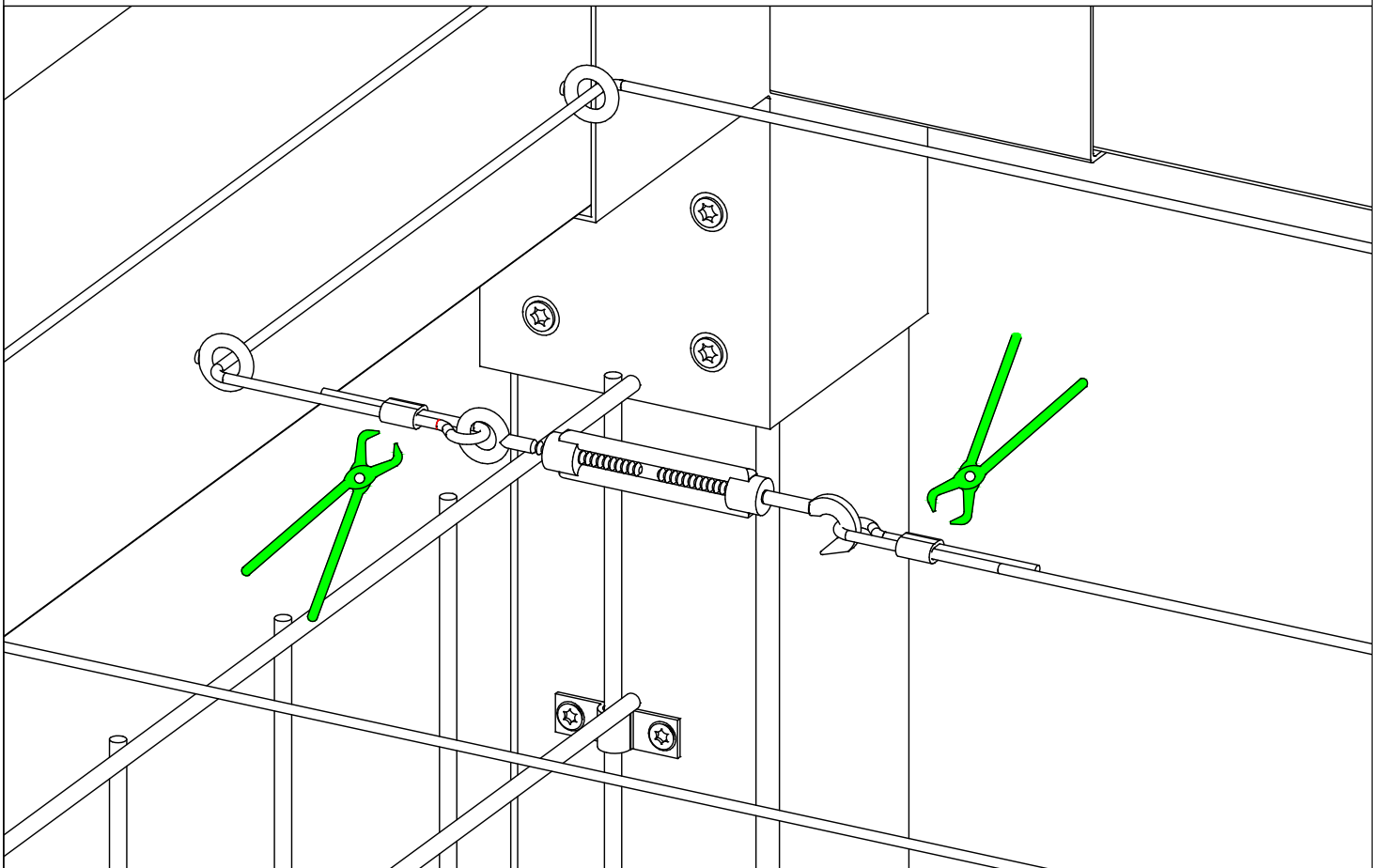

DK: Alt bør efterspændes med jævne mellemrum.

Se [www.plus.dk](http://www.plus.dk) for yderligere information og vedligehold af materialer.

SE: Allt bör efterspännas med jämna mellanrum.

Se [www.plus.dk](http://www.plus.dk) för ytterligare information och underhåll av materialet.

DE: Alles sollte in regelmäßigen Abständen angezogen werden.

Weitere Informationen und Pflegehinweise finden Sie unter [www.plus.dk](http://www.plus.dk)

UK: Everything should be tightened at regular intervals.

See [www.plus.dk](http://www.plus.dk) for further information and maintenance of materials.

FR: Le tout doit être resserré à intervalles réguliers.

Consultez [www.plus.dk](http://www.plus.dk) pour plus d'informations sur l'entretien des matériaux.

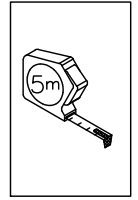
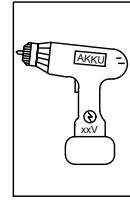
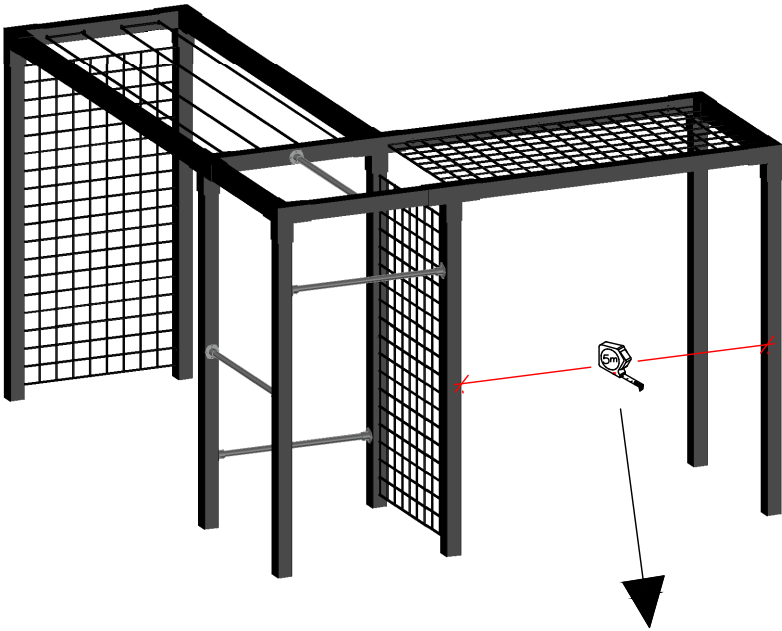

**Viktigt - Wichtig - Important - Viktig..!**

- DK: Træplanker forbores stille og roligt. (3 mm)
- SE: Träplankor förborra lugnt och försiktigt. (3 mm)
- DE: Holzplanken vorbohren vorsichtig und langsam. (3 mm)
- UK: Wood planks are pre-drilled quietly and calmly. (3 mm)
- FR: Planches de bois pré-percer soigneusement. (3 mm)



**180 cm...!**

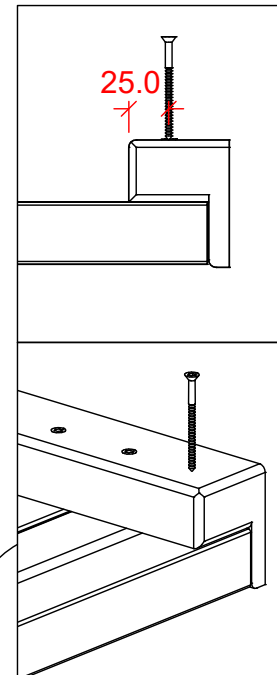
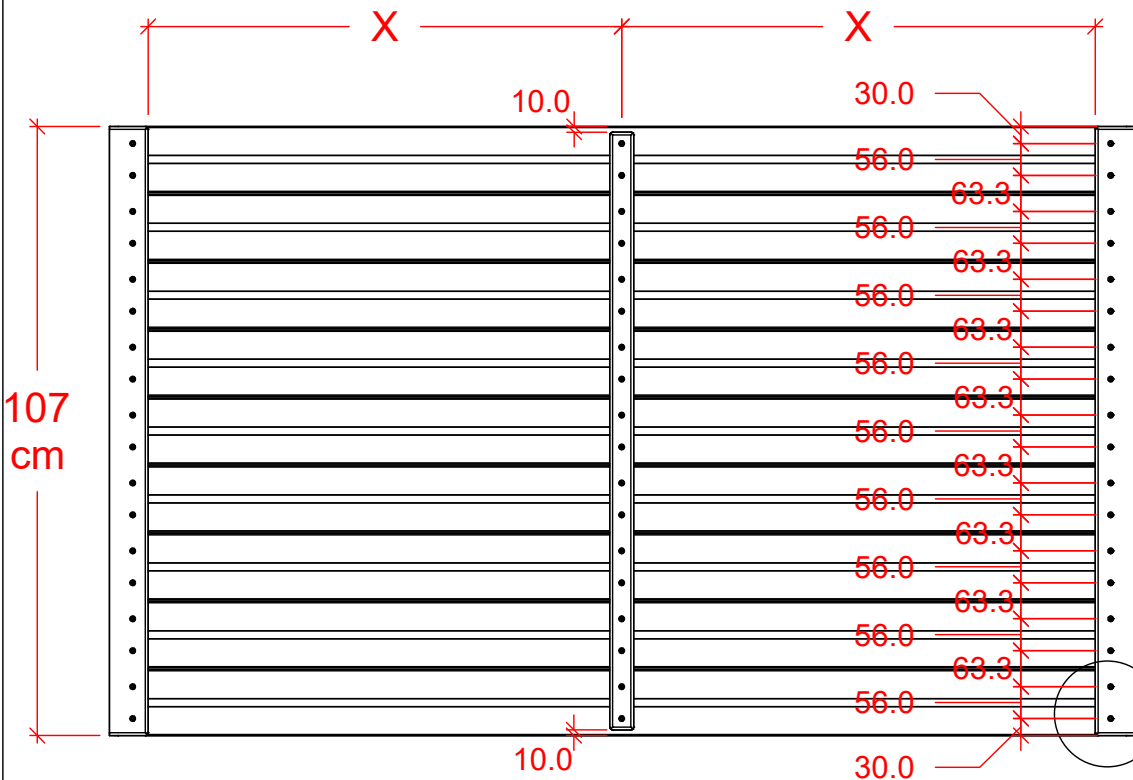
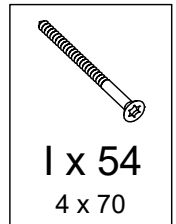
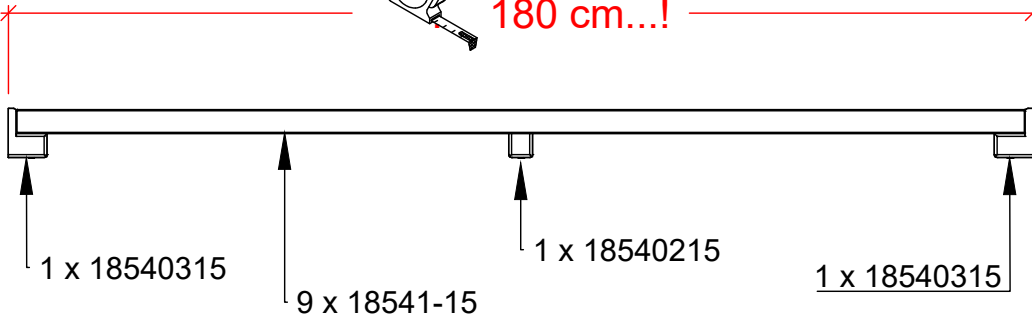

- DK: Yderste brædder helt ud til kanten, øvrige brædder fordeles jævnt (3-4 mm mellemrum).
- SE: Yttersta brädor ända ut till kanten, övriga brädor fördelas jämnt (3-4 mm mellanrum).
- DE: Äußerste Bretter bis zum Rand, andere Bretter gleichmäßig verteilt (3-4 mm Spalt).
- UK: Outer boards all the way to the edge, other boards evenly spaced (3-4 mm gap).
- FR: Les planches les plus à l'extérieur jusqu'au bord, les autres planches sont réparties uniformément (3-4 mm d'écart).

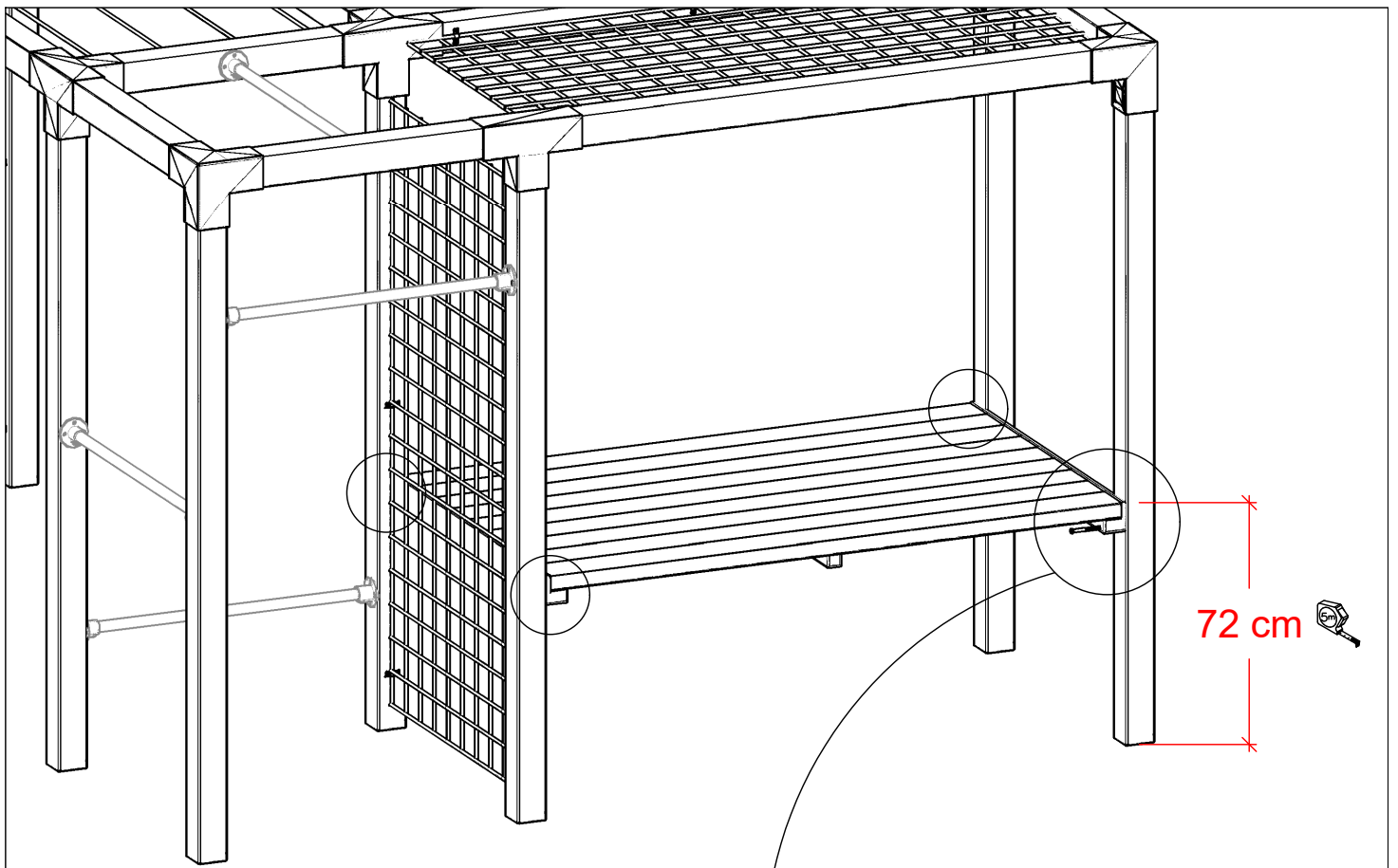

72 cm

