

# 16739-1/167390-1

# PLUS

**CE** DS/EN 71-8

**Advarsel. Kun til privat brug.  
Warning. Nur für privaten Gebrauch.  
Varning: Endast för privat bruk.  
Warning. For private use only.  
Avertissement. Réservé à un usage privé.**



*Fra 3 år  
Von 3 Jahren  
Från 3 år  
From 3 years  
A partir de 3 ans*

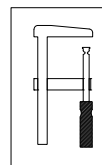
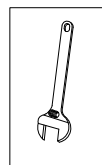
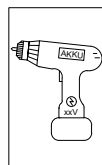
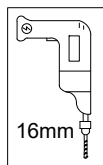
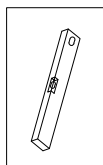
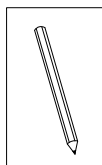
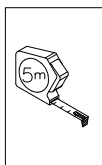

**PLUS A/S, Ådalen 13B, DK - 6600 Vejen  
WWW.plus.dk, plus@plus.dk**

Senest revideret:  
Letzte Änderung:  
Senast reviderat:  
Last updated:  
Dernière révision:  
12 - 2024

## Placering:

Legehuset skal placeres frit, så der mindst er 2 m til nærmeste høje forhindring, som f.eks. gyngestativ, redskabsrum, træer eller lignende man kan kravle op på.

Gulvet anbringes så det er plant.

På punktfundament f.eks. fliser, og med en fugtspærre mellem fliser og bundlægter

(medfølger ikke).

Trædelene er ubehandlede og **skal** males inden montage.

Alle overflader (indvendigt og udvendigt) påføres en transparent eller heldækkende træbeskyttelse.

Tagkonstruktionen bør af hensyn til holdbarhed og sikkerhed beklædes med tagpap (16739-1 medfølger ikke).

*Der må ikke ændres på konstruktionen.*

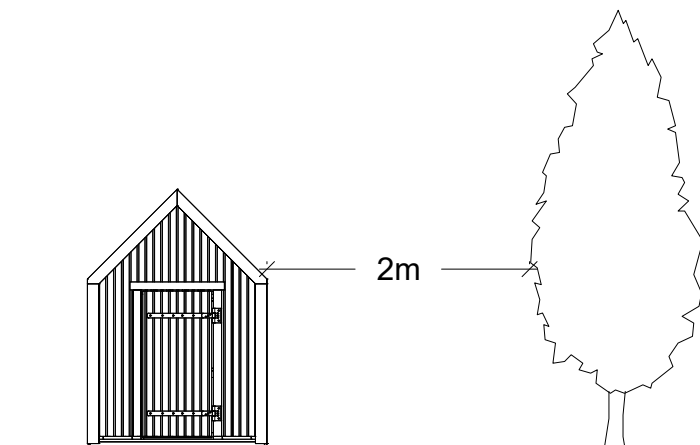

## Vedligeholdelse:

*Det er vigtigt at holde øje med at legehuset er i orden.*

*Kontroller jævnligt og mindst hver 6 md. legehuset:*

- *At konstruktion er intakt, evt udskiftning af slidte eller defekte dele.*
- *Bevægelige dele skal smøres med syrefri olie.*

## UBEHANDLEDE PRODUKTER:

På Plus.dk kan du finde yderligere information om hvordan du skal efterbehandle og vedligeholde produktet.

Sådan gør du:

Klik på  i topmenuen for at finde hjælp. Søg på **produkt navn** eller **varenummer** i søgefeltet på plus.dk og find alle de gode links med nyttig viden under det enkelte produkt.

**Gem denne vejledning til senere brug.**

## Platzierung:

Das Spielhaus muss frei platziert werden, so dass ein Abstand von mindestens 2 Meter zum nächstgelegenen hohen Hindernis beträgt, wie z.B. eine Schaukel, ein Geräteschuppen, Bäume oder ähnliches, auf die Sie klettern können.

Der Boden sollte so platziert werden, dass er eben ist.

Auf einem Punktfundament, z. B. Fliesen, und mit einer Feuchtigkeitssperre zwischen den Fliesen und dem Boden (nicht enthalten).

Die Holzteile sind unbehandelt und müssen vor der Verlegung gestrichen werden.

Alle Oberflächen (innen und außen) werden mit einem transparenten oder flächendeckenden Holzschutz beschichtet.

Aus Gründen der Haltbarkeit und Sicherheit sollte die Dachkonstruktion mit Dachpappe

(16739-1 nicht im Lieferumfang enthalten).

*Die Struktur darf nicht verändert werden.*

## Wartung:

*Es ist wichtig, das Spielhaus in gutem Zustand zu halten.*

*Kontrollieren Sie es regelmäßig, mindestens aber alle 6 Monate. das Spielhaus:*

- *Dass die Struktur intakt ist, eventuell verschlissene oder defekte Teile austauschen.*
- *Bewegliche Teile müssen mit säurefreiem Öl geschmiert werden.*

## UNBEHANDELTE PRODUKTE:

Auf Plus.dk finden Sie weitere Informationen darüber, wie das Produkt zu behandeln und zu pflegen ist.

Wie man es macht:

Klicken Sie  im oberen Menü auf „Hilfe“. Suchen Sie nach dem Produktnamen oder der Artikelnummer im Suchfeld auf

plus.dk und finden Sie alle guten Links mit nützlichen Informationen unter dem jeweiligen Produkt.

**Speichern Sie diesen Leitfaden für den späteren Gebrauch.**

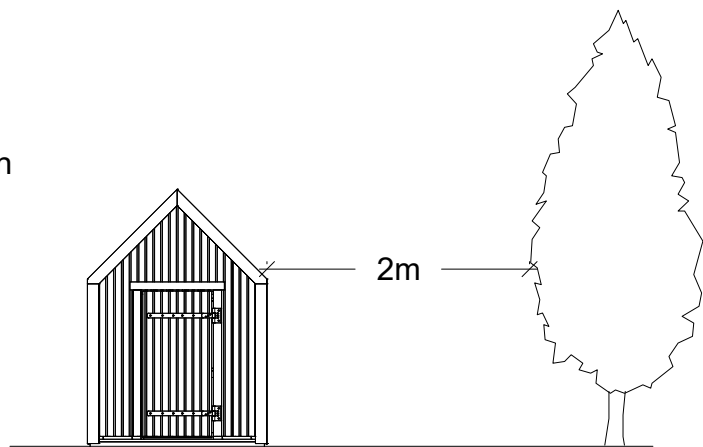

## Placering:

Lekstugan måste placeras fritt så att det är minst

2 meter till närmaste höga hinder,

t.ex. gungställning, redskapsbod,

träd eller liknande som man kan klättra upp i.

Golvet ska vara placerat så att det är plant.

På ett punktfundament, t.ex. kakel, och med en

fuktspärr mellan plattorna och underlaget

(ingår ej).

Trädelarna är obehandlade och måste målas före installation.

Alla ytor (invändigt och utvändigt) måste täckas med ett transparent eller heltäckande träskydd.

För hållbarhetens och säkerhetens skull bör takkonstruktionen täckas med takpapp

(16739-1 ingår ej).

*Gör inga ändringar i konstruktionen.*

## Underhåll:

*Det är viktigt att hålla lekstugan i gott skick.*

*Kontrollera regelbundet och minst var 6:e månad. lekstugan:*

- *Att konstruktionen är intakt, byt vid behov ut slitna eller defekta delar.*
- *Rörliga delar måste smörjas med syrafri olja.*

## OBEHANDLADE PRODUKTER:

På Plus.dk hittar du mer information om hur du ska behandla och underhålla produkten.

Hur du gör det:

Klicka i  toppmenyn för att hitta hjälp. Sök efter produktnamn eller artikelnummer i sökfältet på

plus.dk och hitta alla bra länkar med användbar information under den enskilda produkten.

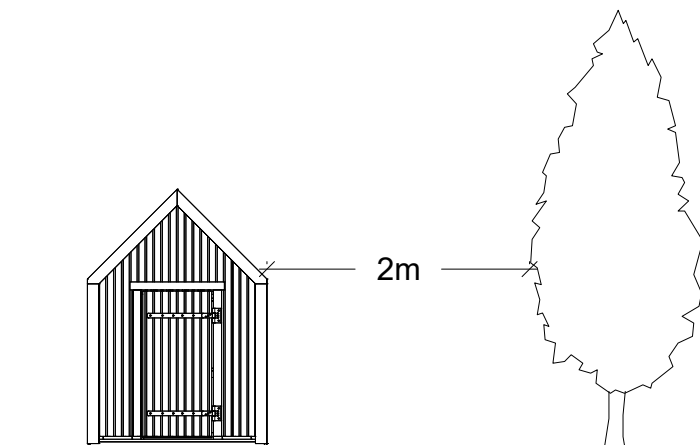

**Spara den här guiden för senare användning.**

## Placement:

The playhouse must be placed freely so that there is at least 2 metres to the nearest high obstacle, such as a swing set, tool shed, trees or similar that you can climb up.

The floor should be placed so that it is level.

On a point foundation, e.g. tiles, and with a moisture barrier between the tiles and the base

(not included).

The wooden parts are untreated and must be painted before installation.

All surfaces (interior and exterior) are coated with a transparent or full-coverage wood protection.

For durability and safety, the roof structure should be covered with roofing felt

(16739-1 not included).

*Do not modify the structure.*

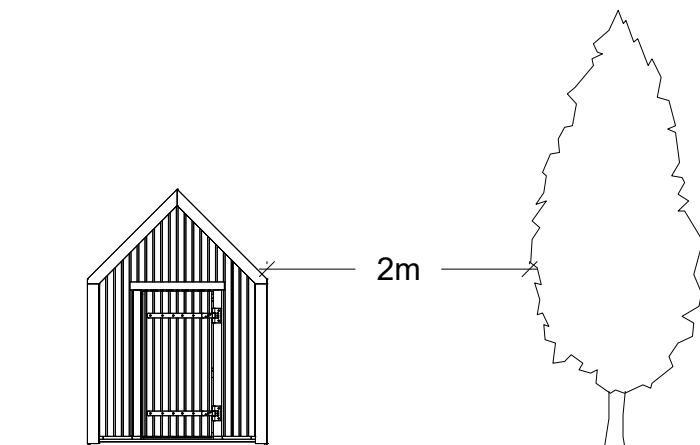

## Maintenance:

*It is important to keep the playhouse in good condition.*

*Check regularly and at least every 6 months. the playhouse:*

- *That the structure is intact, if necessary replace worn or defective parts.*
- *Moving parts must be lubricated with acid-free oil.*

## UNTREATED PRODUCTS:

On Plus.dk you can find further information on how to treat and maintain the product.

How to do it:

Click in the top  menu to find help. Search by product name or item number in the search bar on plus.dk and find all the great links with useful information under the individual product.

**Save this guide for later use.**

## Placement :

La maison de jeu doit être placée librement de manière à ce qu'il y ait au moins

2 mètres de l'obstacle élevé le plus proche, comme une balançoire, une cabane à outils, un arbre ou autre, sur lequel il est possible de grimper.

Le plancher doit être placé de manière à être de niveau.

Sur une fondation ponctuelle, par exemple des

carreaux, et avec une barrière anti-humidité entre les dalles et la base (non fournie).

(non inclus).

Les parties en bois ne sont pas traitées et doivent être peintes avant l'installation.

Toutes les surfaces (intérieures et extérieures) sont recouvertes d'une protection transparente ou complète pour le bois.

Pour des raisons de durabilité et de sécurité, la structure du toit doit être recouverte d'un feutre de toiture

(16739-1 non inclus).

*Ne pas modifier la structure.*

## Entretien :

*Il est important de maintenir la maison de jeu en bon état.*

*Vérifier régulièrement et au moins tous les 6 mois. la maison de jeu :*

- *Que la structure est intacte, si nécessaire remplacez les pièces usées ou défectueuses.*
- *Les pièces mobiles doivent être lubrifiées avec de l'huile exempte d'acide.*

## LES PRODUITS NON TRAITÉS :

Sur Plus.dk, vous trouverez de plus amples informations sur la manière de traiter et d'entretenir le produit.

## Comment procéder :

Cliquez sur  le menu supérieur pour trouver de l'aide. Faites une recherche par nom de produit ou par numéro d'article dans la barre de recherche de

plus.dk et trouvez tous les liens utiles sous le produit concerné.

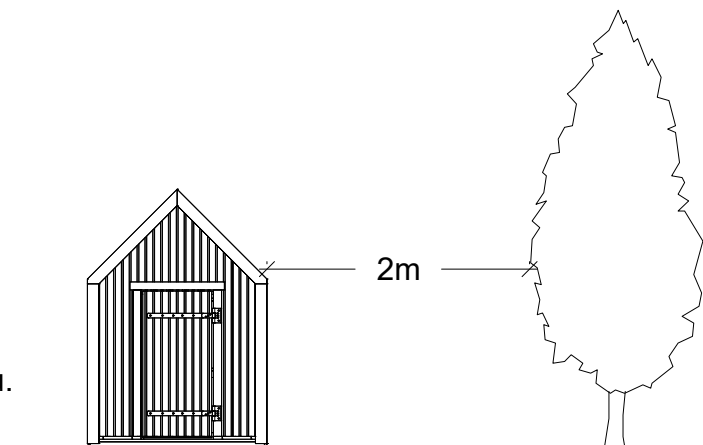

**Sauvegardez ce guide pour une utilisation ultérieure.**

# 16739-1

Tolerance +/- 5mm

POS	Antal	1673901	cm
A-1	1		120x140
B-1	2		110x140
B-2	2		140
C-1	1		111x163
C-2	2		9,5x111
C-3	1		111x163
C-4	2		9,5x64
C-5	2		9,5x45
C-6	1		140
C-7	1		9,2x110
C-8	1		9,2x66
D-1	2		89x115
D-2	2		5,1x89
D-3	4		9,5x89
D-4	2		6,7x89
D-5	4		8x110
D-6	4		8x90
E-1			48x101
E-2			1,8x50
E-3			1,8x100



x 26  
5 x 90mm



x 12  
5 x 70mm



x 160  
3,5 x 50mm

## 1673902

2443-1

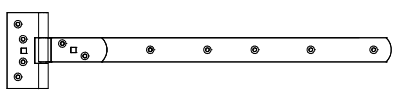



x 2

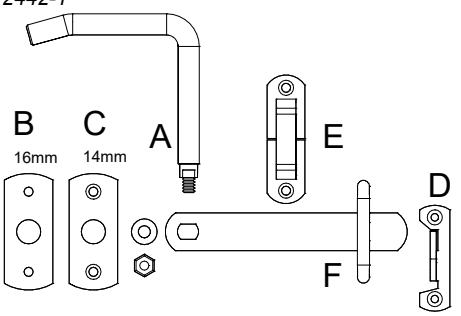

x 22  
5 x 50mm

2442-1





x 6  
4 x 25mm



x 2  
4 x 30mm

# 16739-1

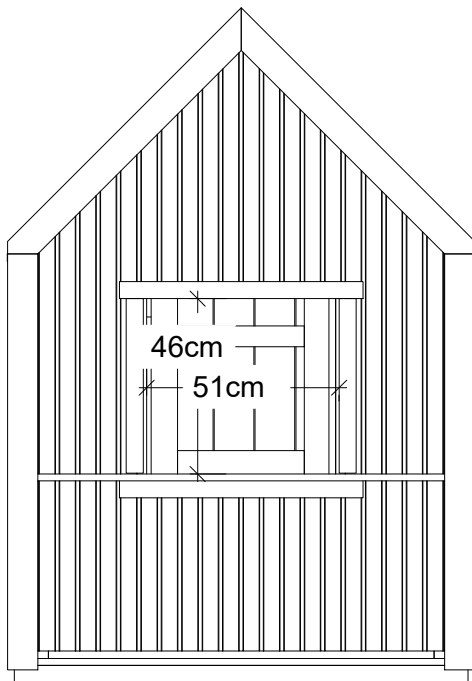
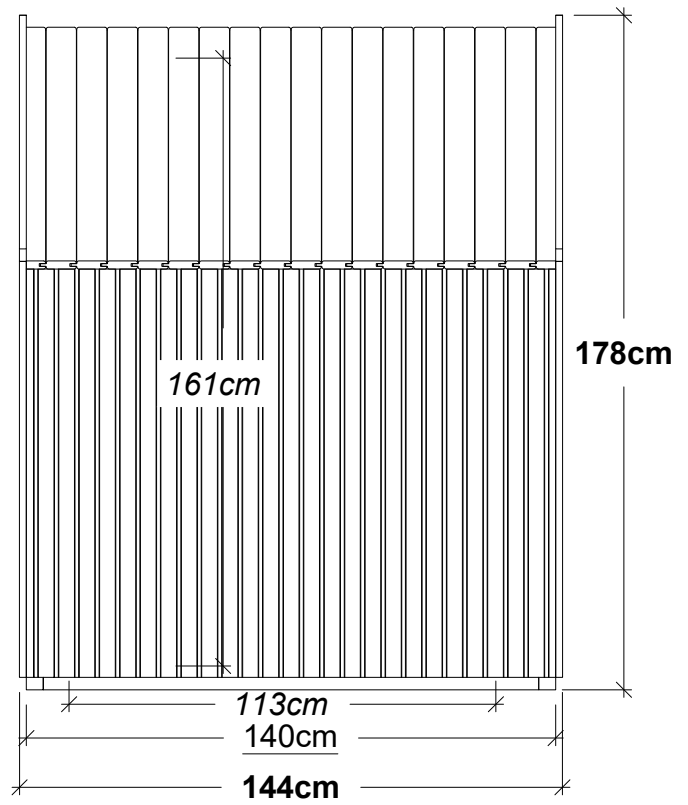
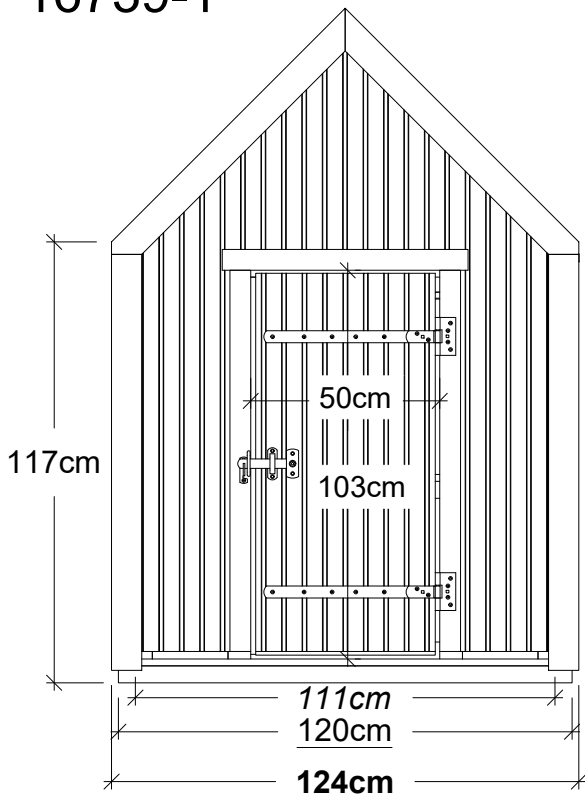

Grundareal/ Bodenfläche/Byggyta/Floor area/  
Surface de base: 1,2 x 1,4 = 1,68m<sup>2</sup>

Tag/Dach/Tak/ Roof/Le toit : 1,4 x 0,89 m x 2

*Døren kan placeres i venstre eller højre side.*

*Die Tür kann auf der linken oder rechten Seite angebracht werden.*

*Dörren kan placeras på vänster eller höger sida.*

*The door can be placed on the left or right side.*

*La porte peut être placée à gauche ou à droite.*

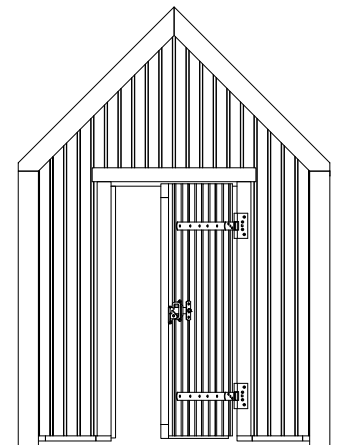
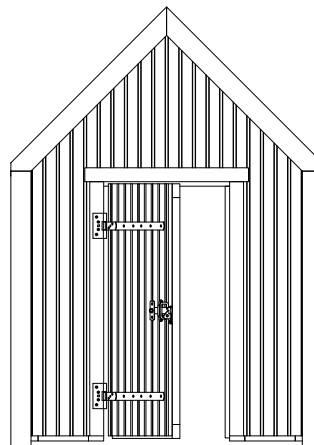



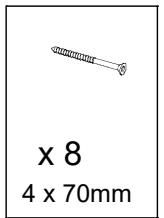
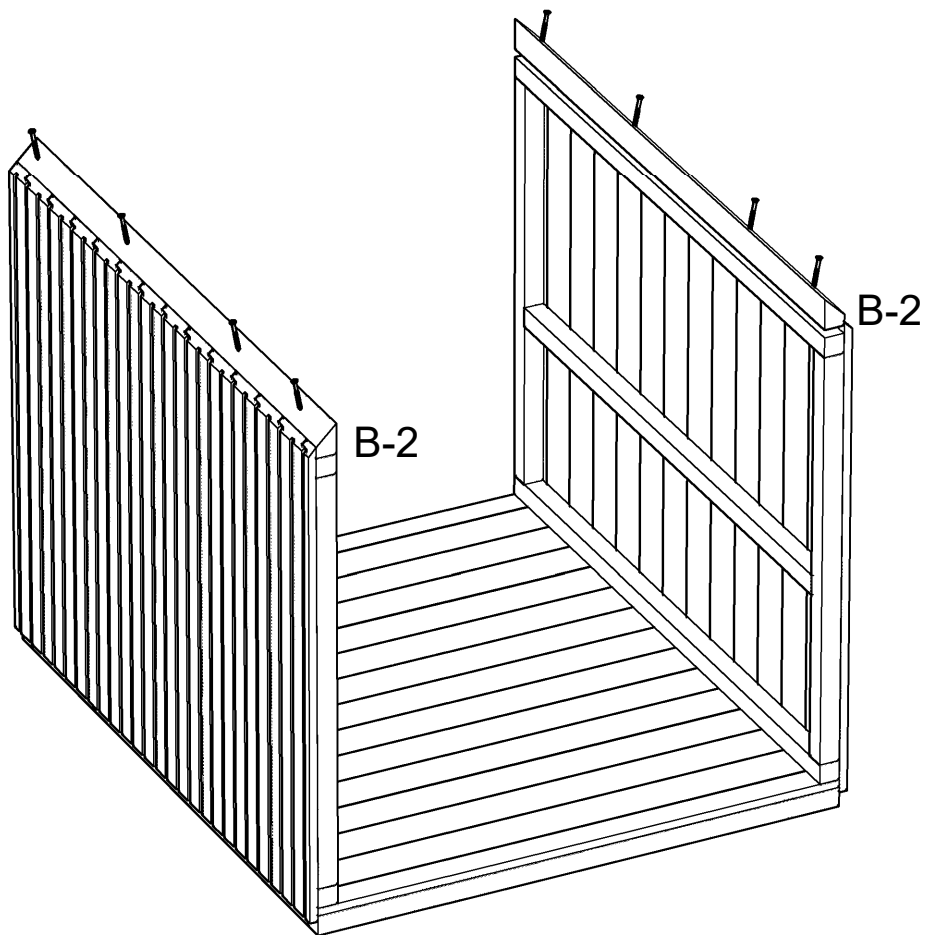
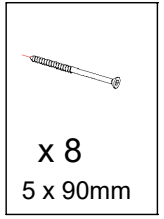
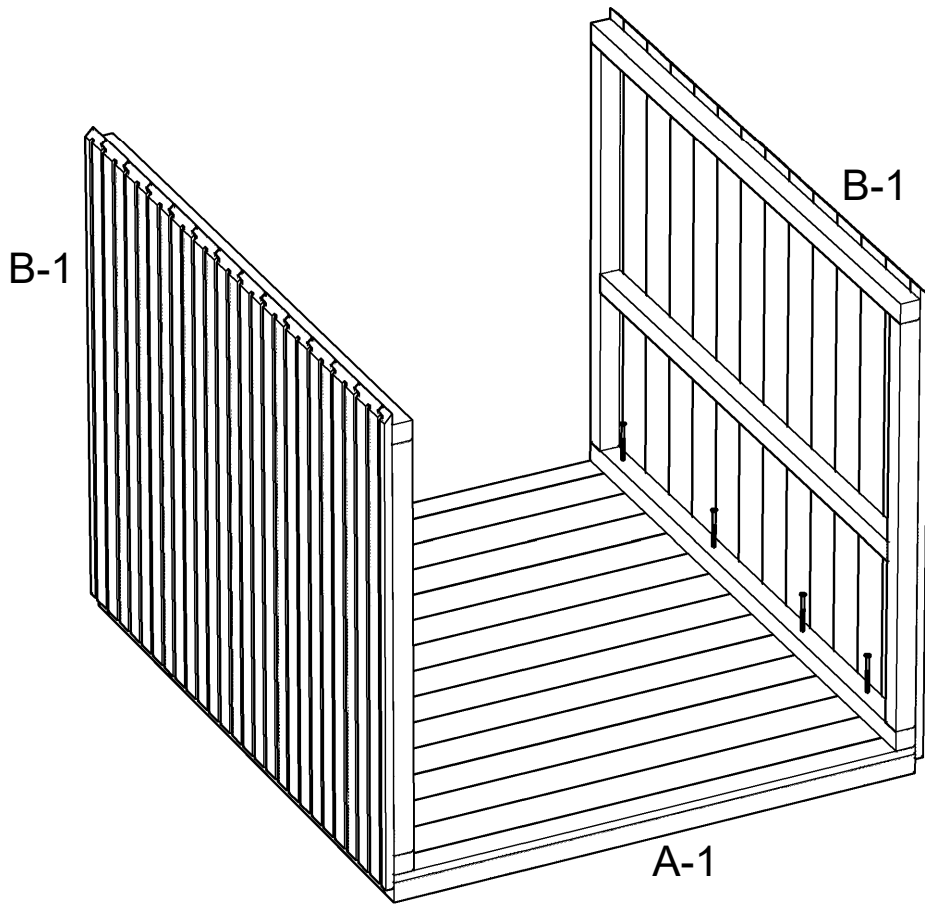

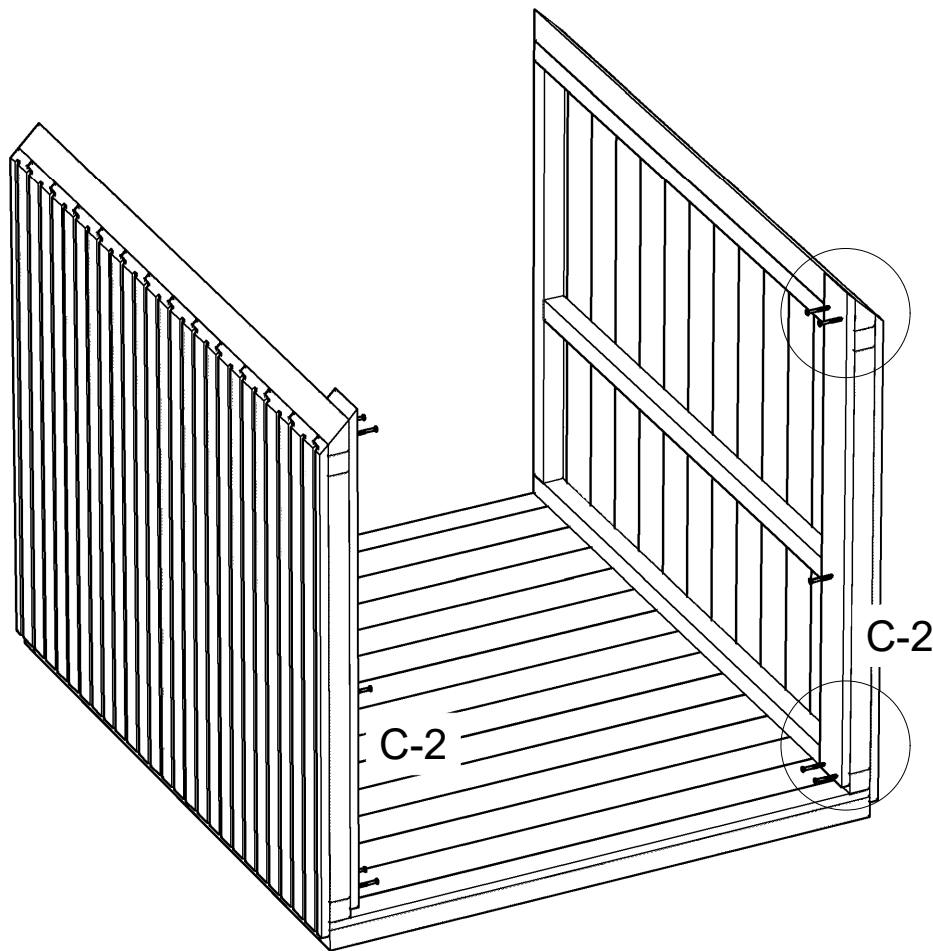

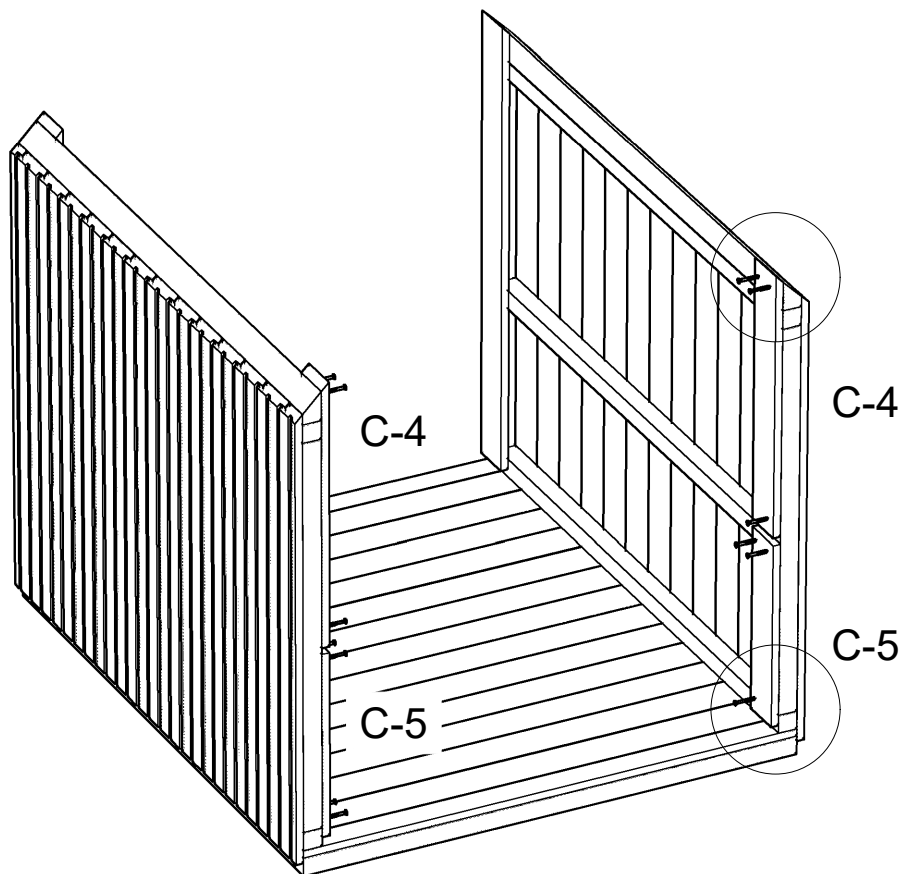
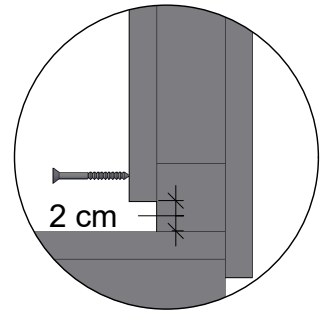
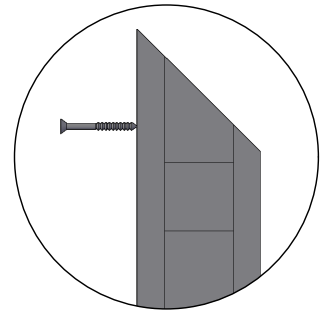

x 10  
3,5 x50mm

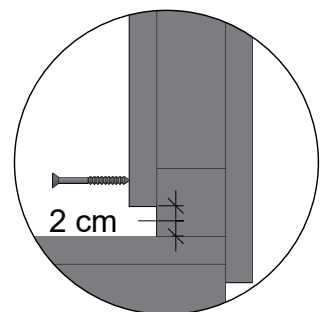
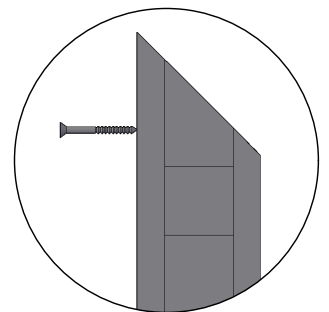

x 14  
3,5 x50mm



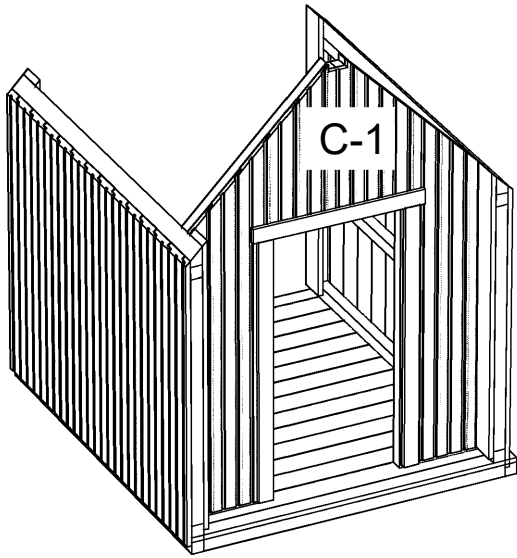

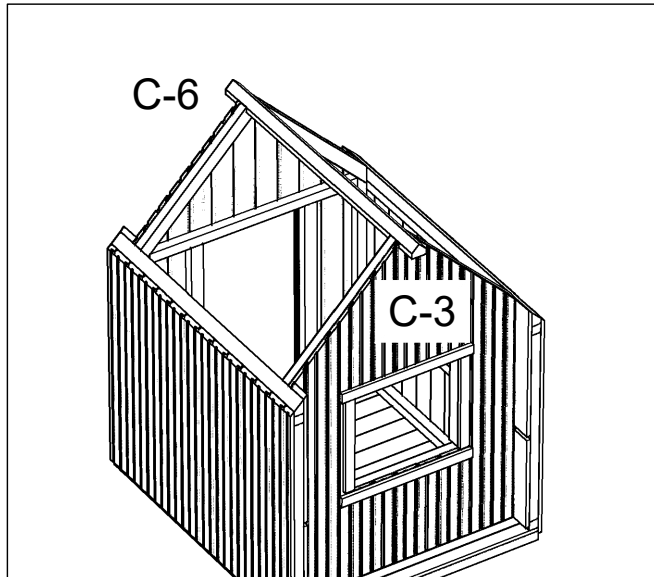
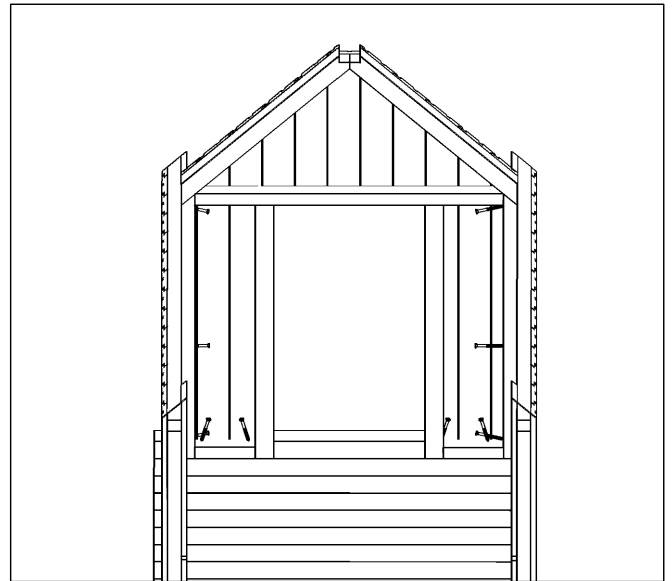

x 10  
5 x 90mm

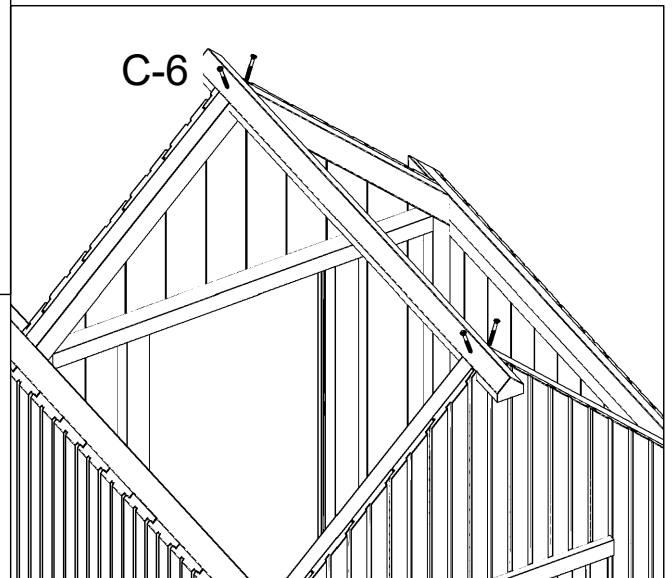

x 4  
4 x 70mm



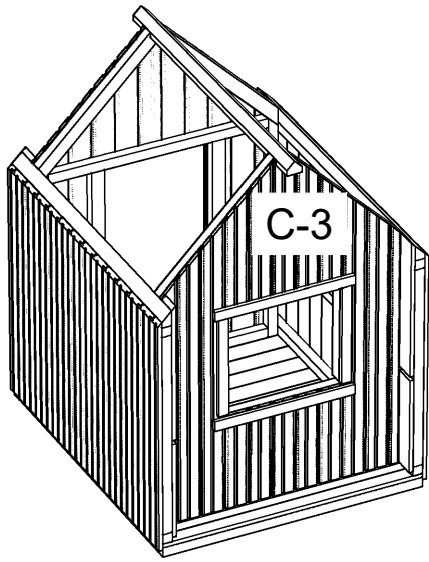

x 8  
5 x 90mm

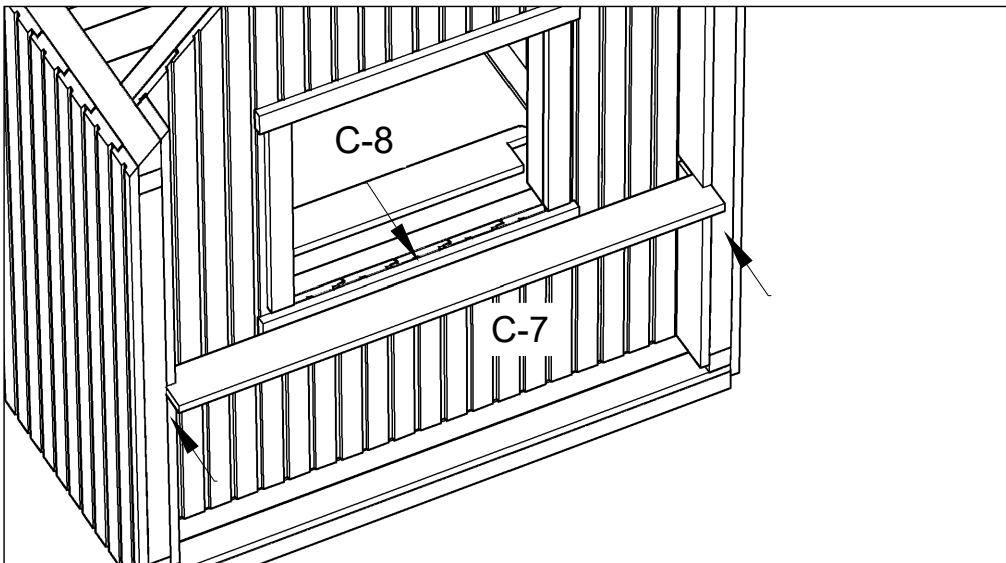
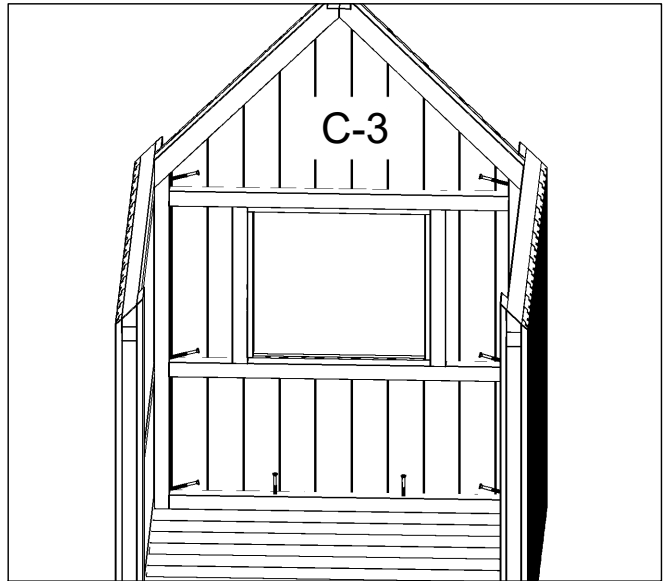

x 6  
3,5 x 50mm

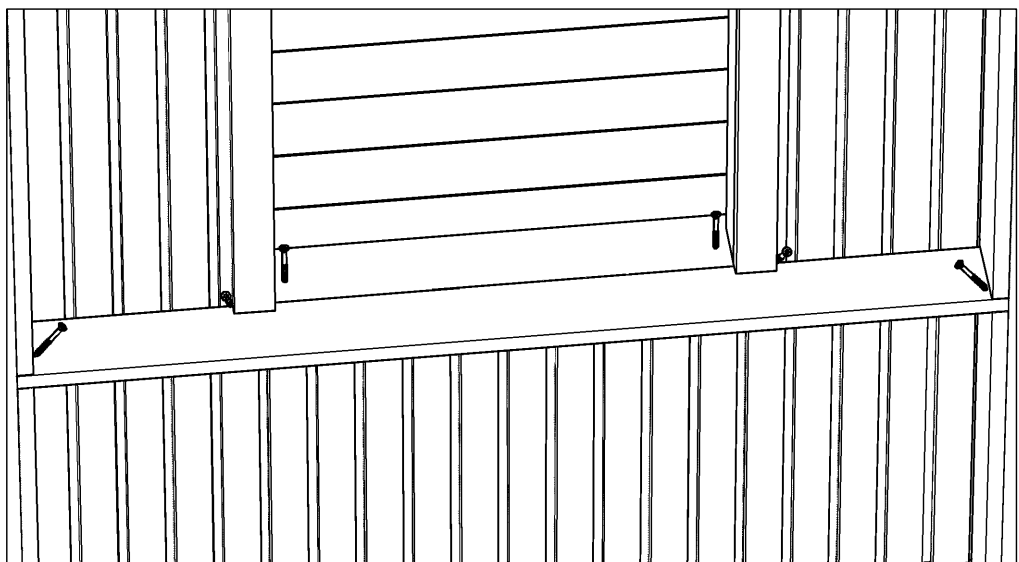

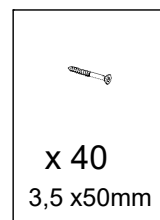
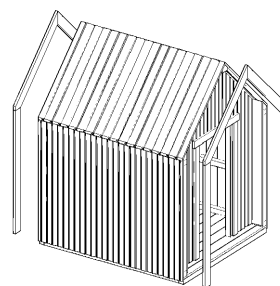
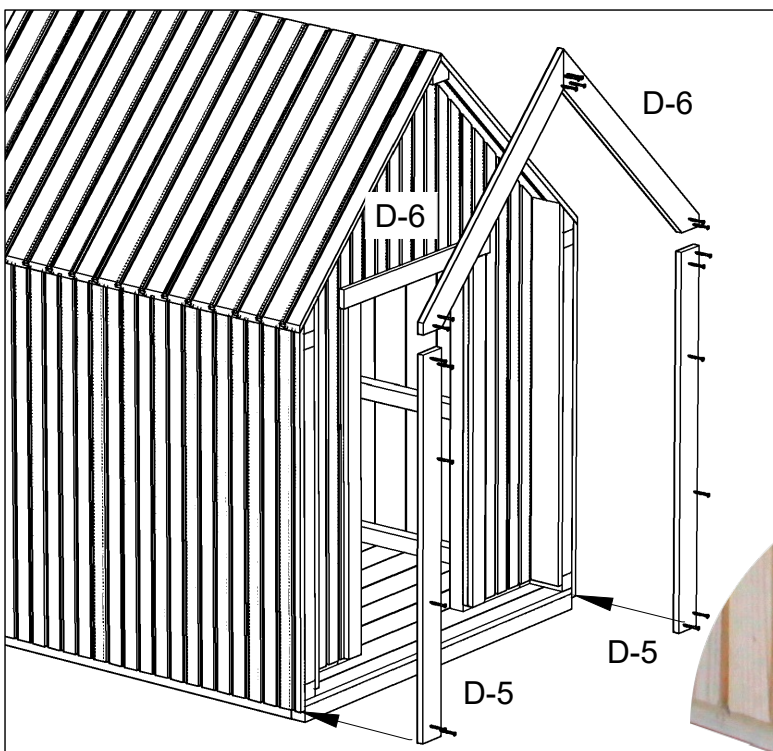
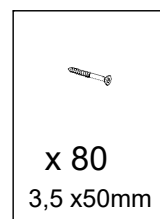
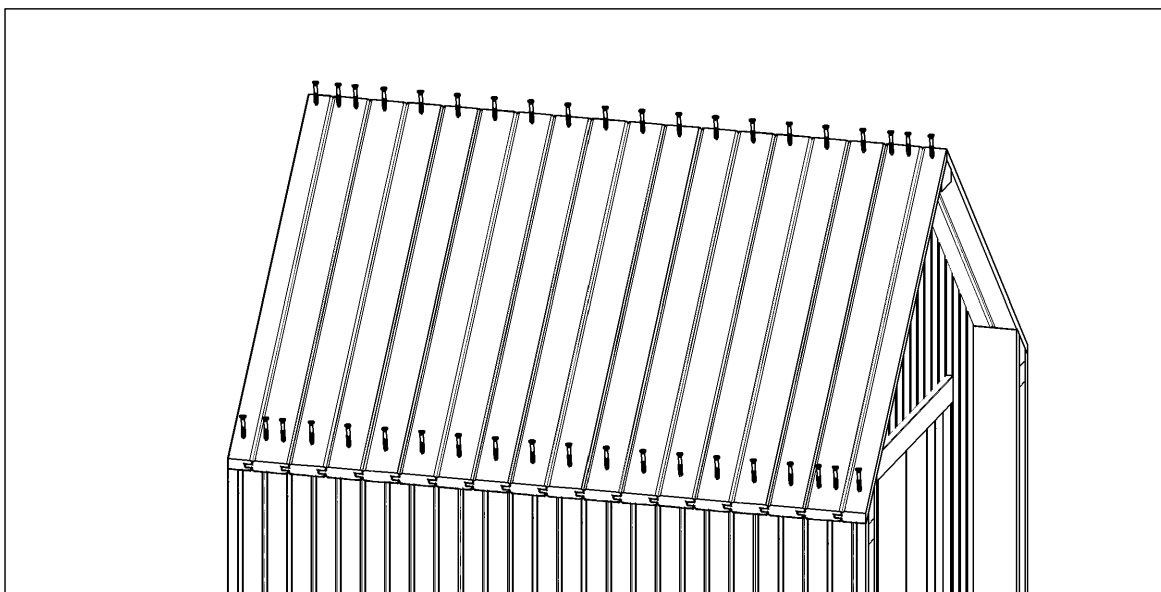
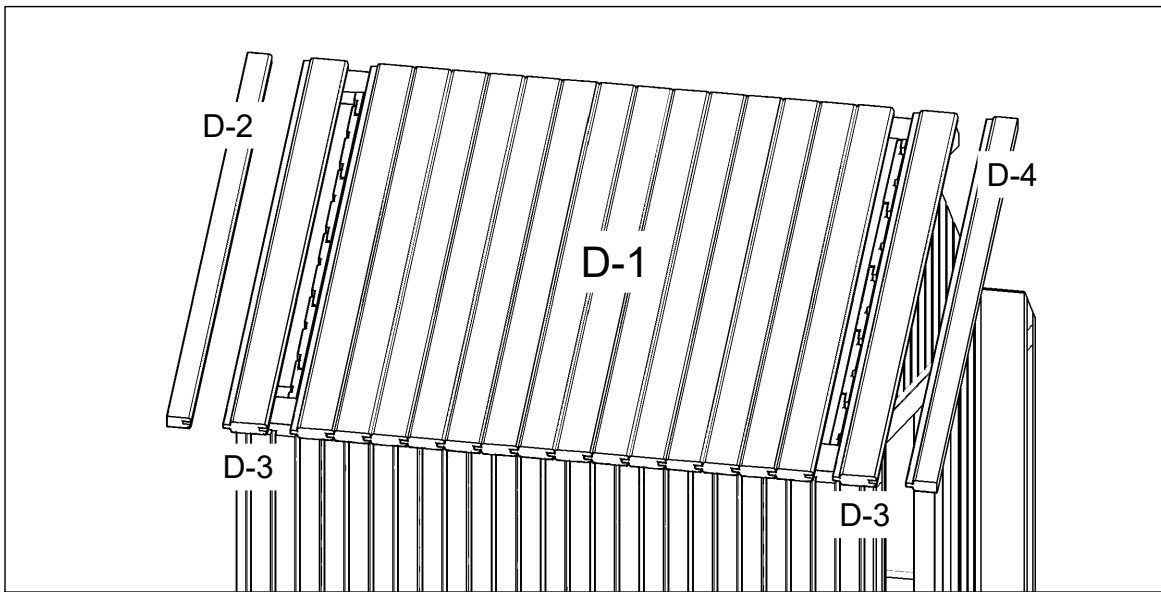

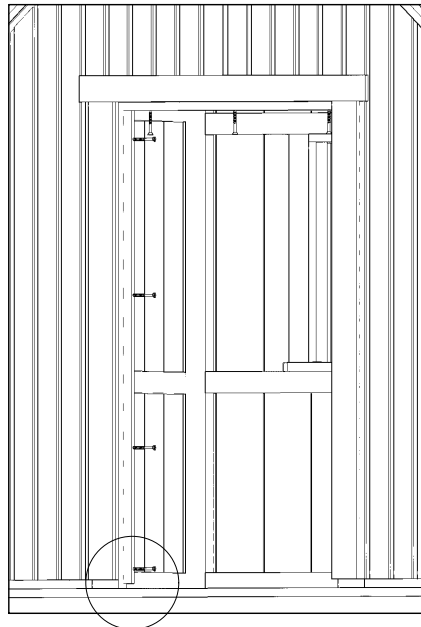
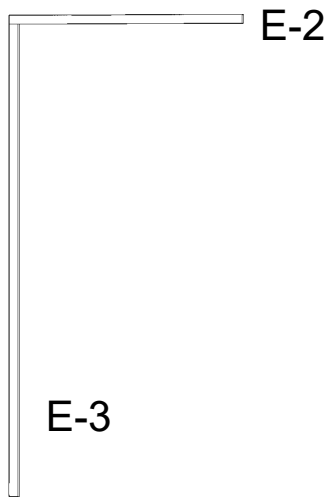

  
 x 7  
 3.5x50mm

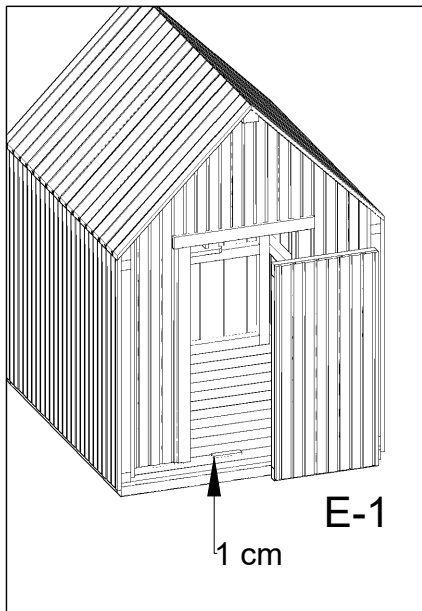
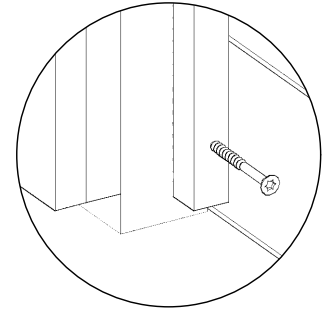

*Brug en kile eller bræt til at løfte døren 1 cm.*

*Verwenden Sie einen Keil oder ein Brett, um die Tür 1 cm anzuheben.*

*Använd en kil/platta för att lyfta dörren 1 cm.*

*Use a wedge/board to lift the door 1 cm.*

*Utiliser une cale/planche pour soulever la porte de 1 cm.*

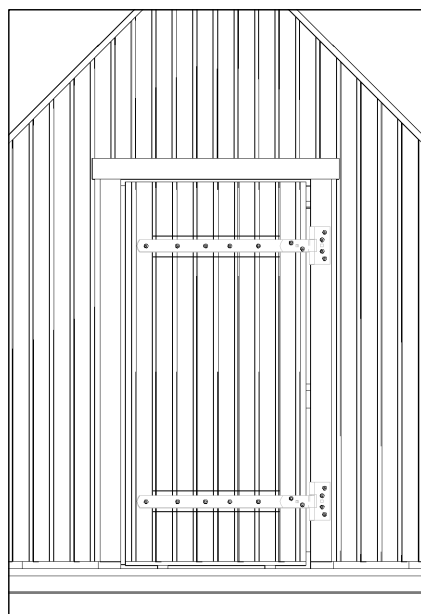
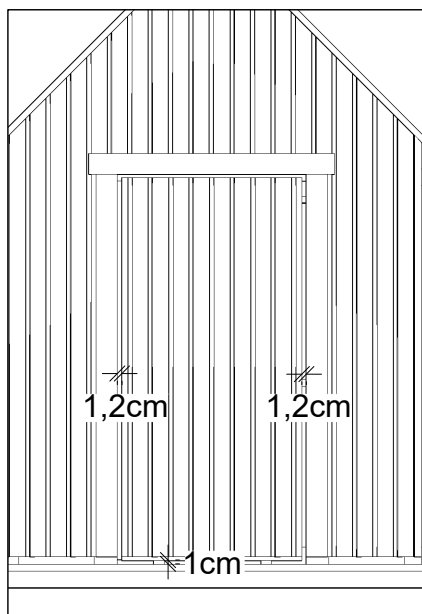

  
 x 22  
 5x50mm

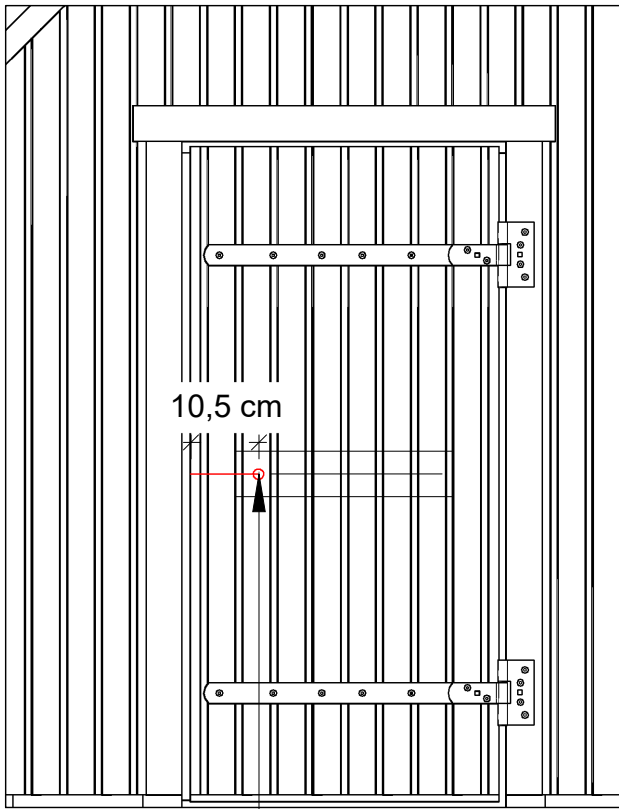

Ø16mm

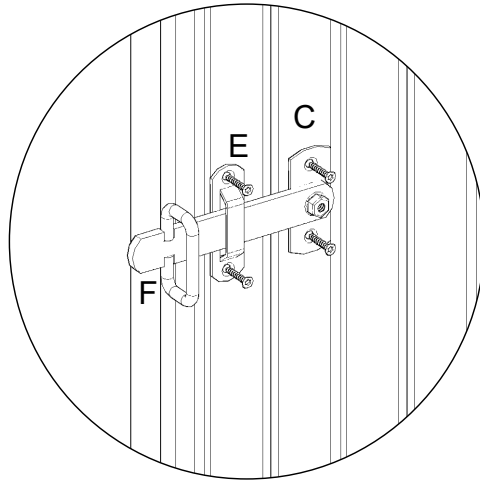
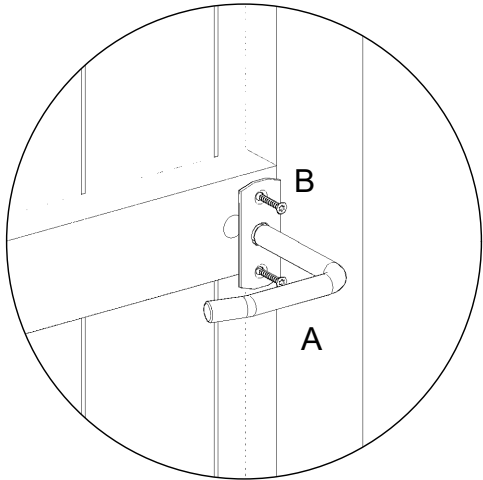
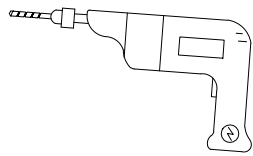

  
x 6  
4x25mm

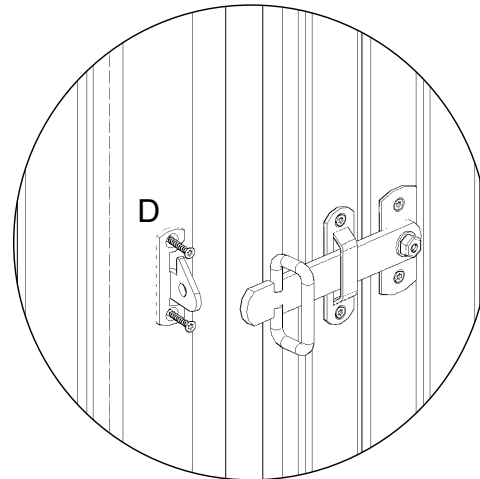

  
x 2  
4x30mm

